



We rank VENDORS by
REVENUE
and
CLIENT MINDSHARE

Forecast : **IT Market in Israel 2012**

*Dr. Jimmy Schwarzkopf's work Copyright STKI@2012
Do not remove source or attribution from any slide, graph or portion of graph*

Dr. Jimmy Schwarzkopf
Managing Partner, STKI
jimmy@stki.info
Tel: +972 9 790 7000



stki.info
IT Knowledge Integrators



- Dr. Schwarzkopf has worked during the last 35 years in all areas of Computer Information Services.
 - IT Analyst as META Group Israeli Research Manager and was named a META Group Research Fellow.
 - As an academic researcher in Entrepreneurship Sciences; has published and presented in the Academy of Management and Babson Conferences and Editorial Board Member of the academic journal "International Journal of Opportunity, Growth and Value Creation".
 - As a consultant in Arthur Andersen Consulting (USA), Booz Allen (USA) and Kesselman & Kesselman.
 - As a systems professional in SCS Computers and the R&D Unit of the Israel Defense Forces.
 - As a sales and marketing professional in Digital Equipment Corporation.
 - Teaching in the MIS department at Ben Gurion University, the TelAviv Yafo Academic College and the Computer School of the IDF.
 - Entrepreneur founding three companies in the IT arena: STKI, store and forward mail and office information systems.
- Dr. Schwarzkopf served on the Board of Directors of Ashot Ashkelon Industries, served as President of the Gymnazia Herzelia Association, Co-founder of the Mashov Political Movement and was a member of the Central Committee of the Labor Party. Major (Rav-Seren) in the reserves, Israel Defense Forces (where he served in an elite unit and later in the R&D unit). Registered Engineer (IS22881), member of MENSA Israel.
- Dr. Schwarzkopf received BSE and MSE degrees (Systems Engineering) from the University of Central Florida. Received a MSIA (Management Information Systems) and is an ABD (in PhD Program) in Systems Science (received (twice) the William Larimer Mellon Scholarship/Award) from Carnegie Mellon University. His doctorate (Management/ Entrepreneurship) he received from Case Western Reserve University.

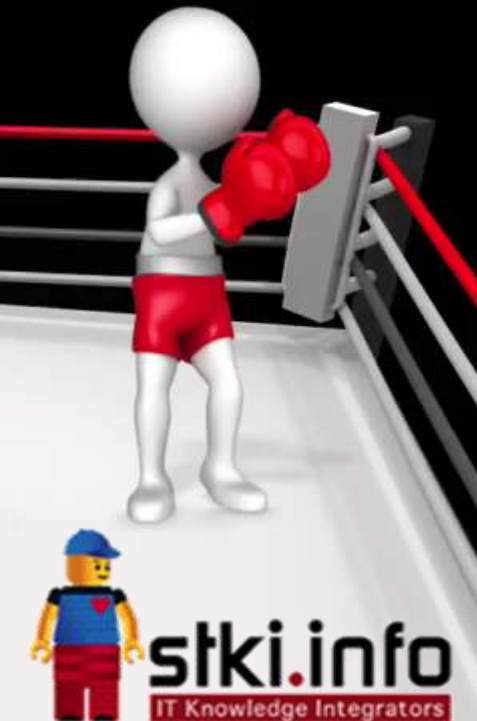

Unlike some research
and advisory firms

STKI

does no consulting
work ,

allowing our research to
be totally unbiased,
with no hidden
agendas to promote
any particular technology
or vendor.



STKI's goal is to help our clients make the right choices in the strategic and financial management of their information technology systems.

Founded in 1992, STKI is the leading market research and strategic analyst firm in Israel, covering the IT infrastructures, IT applications and IT services industry .

Over 20 years of experience in the IT analyst sector and thousands of annual face-to-face interviews with key industry participants have enabled us to establish solid, long-standing relationships with our customers.

Our customers include major IT organizations (government, financial institutions, telecoms, manufacturing, medical, education, etc.) and IT suppliers/vendors (infrastructure and software suppliers, consulting and professional services firms).

STKI works closely with vendor senior management (strategy, business development, and marketing). Where end users are concerned, STKI meets with IT managers as well as with all levels of IT decision making, thereby attaining complete information of processes.

STKI's mission is to advise and analyze users of information technology as well as their suppliers while conducting original research and providing advisory services regarding all parts of the information system puzzle. Israel's foremost IT companies have come to rely on STKI's market-proven experience and expertise.

Our services include:

- Face-to-face meetings
- STKI Analyst House Calls (for both users and vendors)
- CIO STKI "Help Desk"
- Inquiries
- Surveys
- Strategic Marketing & Positioning
- Round Tables for users
- Vendor Discovery Series (Newsletters and workshops)
- In-house Workshops
- CIO Annual Bootcamp
- CTO Annual Bootcamp
- Brainstorming Workshops
- STKI Annual Summit



STKI's Methodology

What STKI analysts did for this report:

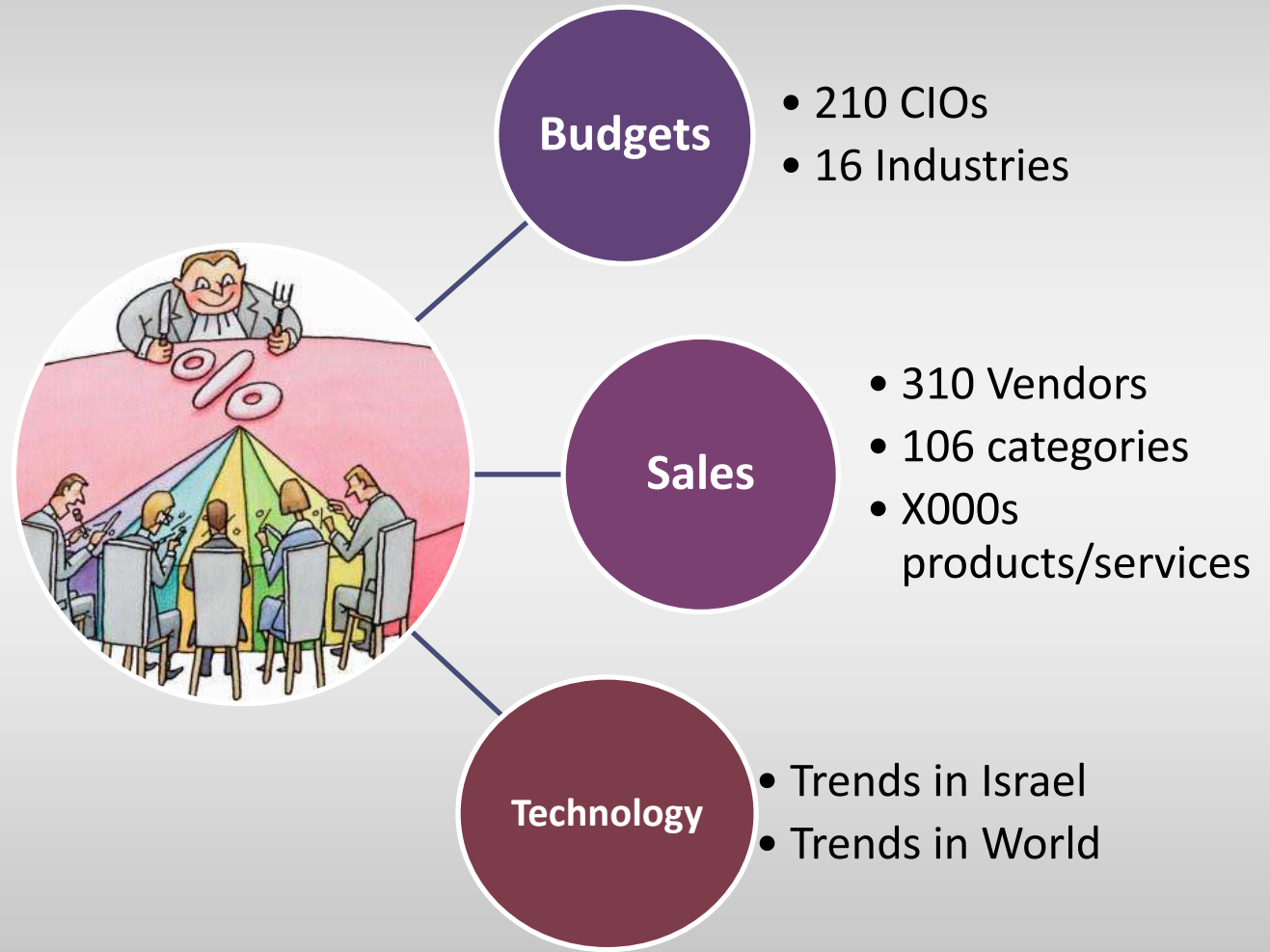

EQUILIBRIUM MODEL.

The sum of all *IT expenditures* (from users) has to be equal to all *IT sales* (from vendors).

Most research firms are either a

"demand-based"

(market information based on data from users of IT)

or

"supply-based"

(market information based on data from IT vendors).

STKI is one of the only research firms using an equilibrium model and the only one in Israel.



STKI's Methodology

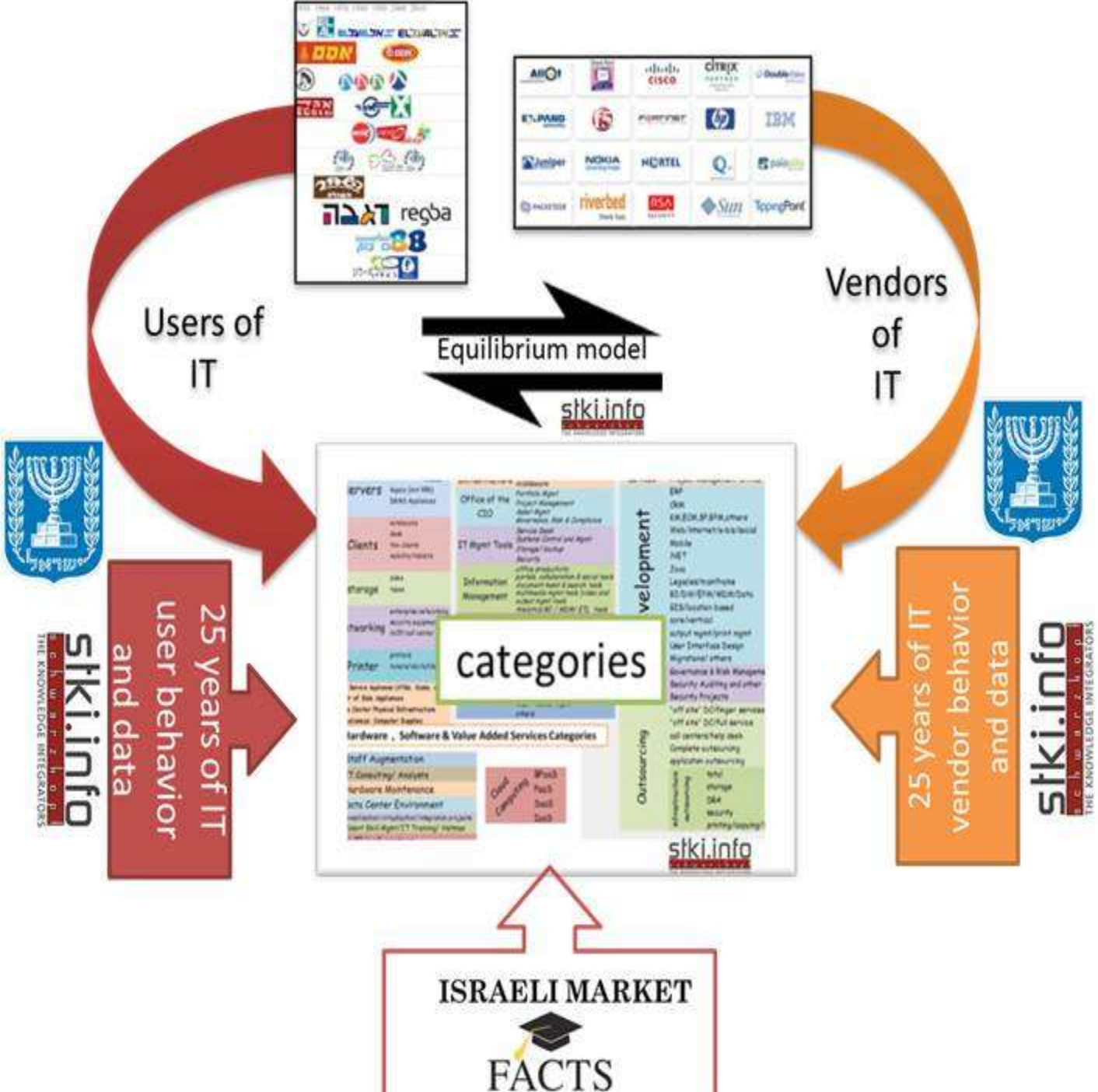

What our study looks at:

- Real revenues of software licenses and maintenance.
- Real revenues of hardware sales.
- Differentiation between new projects and continuing projects. New projects count more.
- We do not include any work/ products for OEMs and military non-IT projects.
- We distinguish between work done by the vendor's employees and work outsourced to another vendor. The revenue is transferred to the vendor actually doing the work.
- Distinguish revenues from projects done in fixed price, cost plus (SLA defined) and staff augmentation (non SLA) projects.
- Differentiate value between work done by high level internal professionals in a project and staff augmentation employees in the clients IT department.
- Take into consideration IT department's view/mindshare of vendor's value in projects/products

We rank VENDORS by
REVENUE
and
CLIENT MINDSHARE

All amounts in M \$ USD



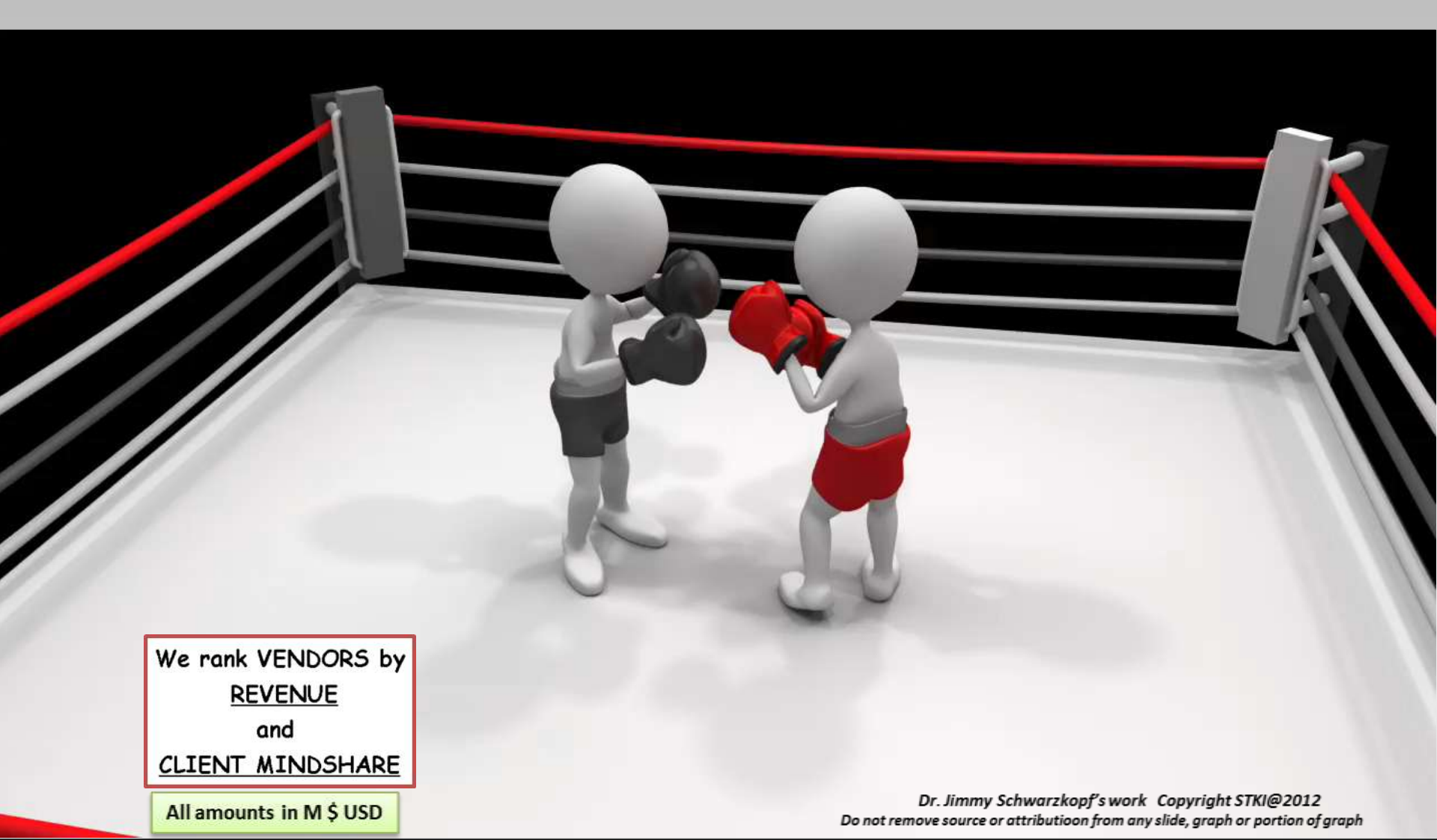

We rank VENDORS by
REVENUE
and
CLIENT MINDSHARE

All amounts in M \$ USD

*Dr. Jimmy Schwarzkopf's work Copyright STKI@2012
Do not remove source or attribution from any slide, graph or portion of graph*

Economic Figures

| Criteria | 2009 | 2010 | 2010 Q4 | 2011 Q1 | 2011 Q2 | 2011 Q3 |
|---|---------------|---------------|---------------|---------------|---------------|---------------|
| GDP (constant prices, 2005, in \$B)* | 189.9 | 199.0 | 50.9 | 51.5 | 51.9 | 52.4 |
| Real GDP growth rate (% change) | 0.8% | 4.8% | 7.2% | 4.7% | 3.5% | 3.4% |
| GDP per capita growth rate (%, 2005 prices) | -0.9% | 2.9% | 8.6% | 5.2% | 2.6% | 5.3% |
| Exports (goods & services), \$B* <i>(As % of GDP)</i> | 75.1 39.5% | 85.3 42.9% | 22.1 43.4% | 22.5 43.7% | 22.6 43.5% | 21.5 41.0% |
| Unemployment rate | 7.6% | 6.6% | 6.5% | 6.0% | 5.5% | 5.6% |



* Using a public exchange rate of 1USD=3.7NIS (2010 average)

** Estimated

Additional Sources: IMF

Real GDP Growth

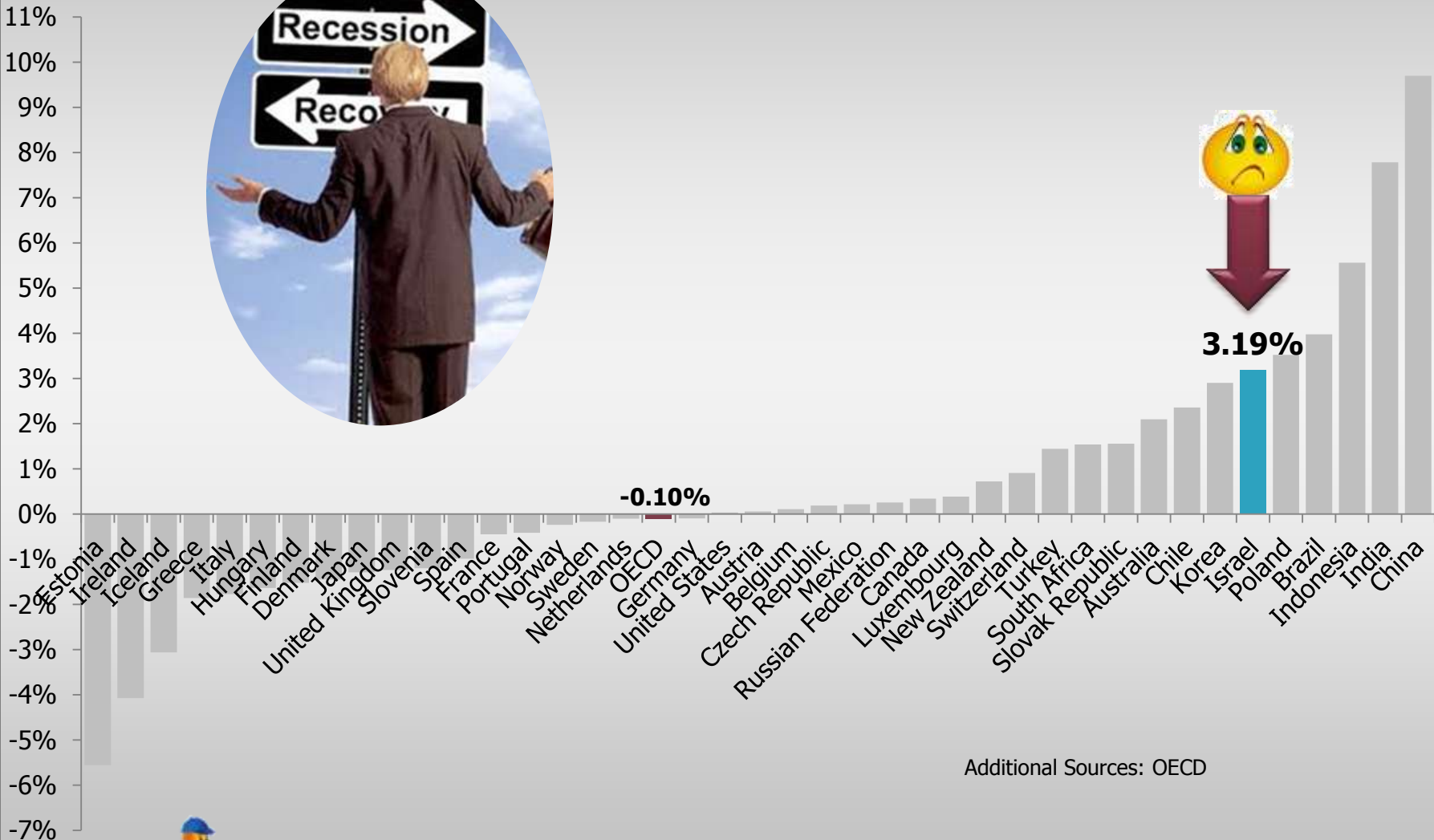

Additional Sources: OECD

GDP per Capita

U.S \$, Current prices, PPP, 2010

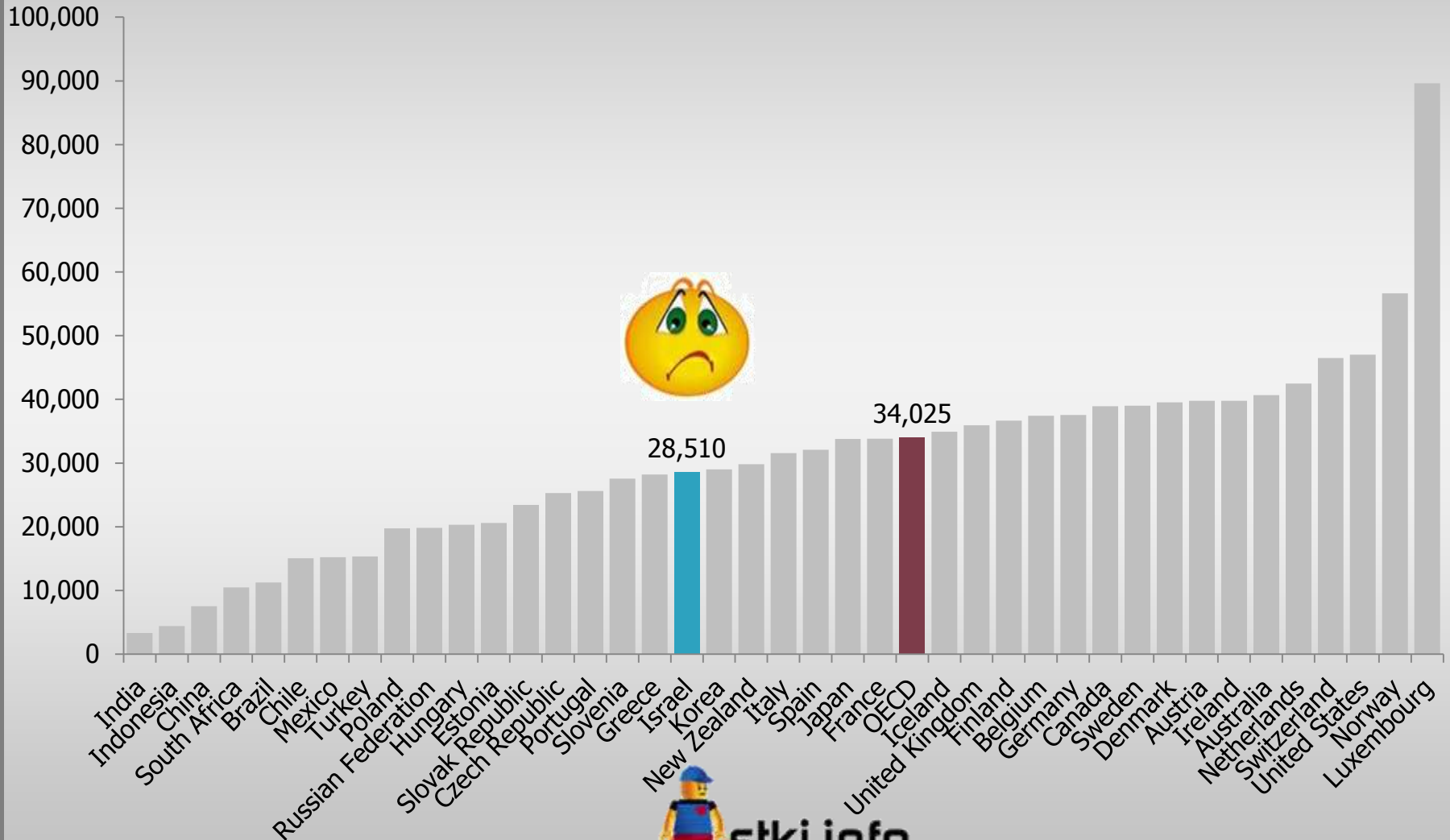

Additional Sources: OECD



Dr. Jimmy Schwarzkopf's work Copyright STKI@2012

Do not remove source or attribution from any slide, graph or portion of graph

Unemployment Rate

3-year average 2008-2010, or latest available period

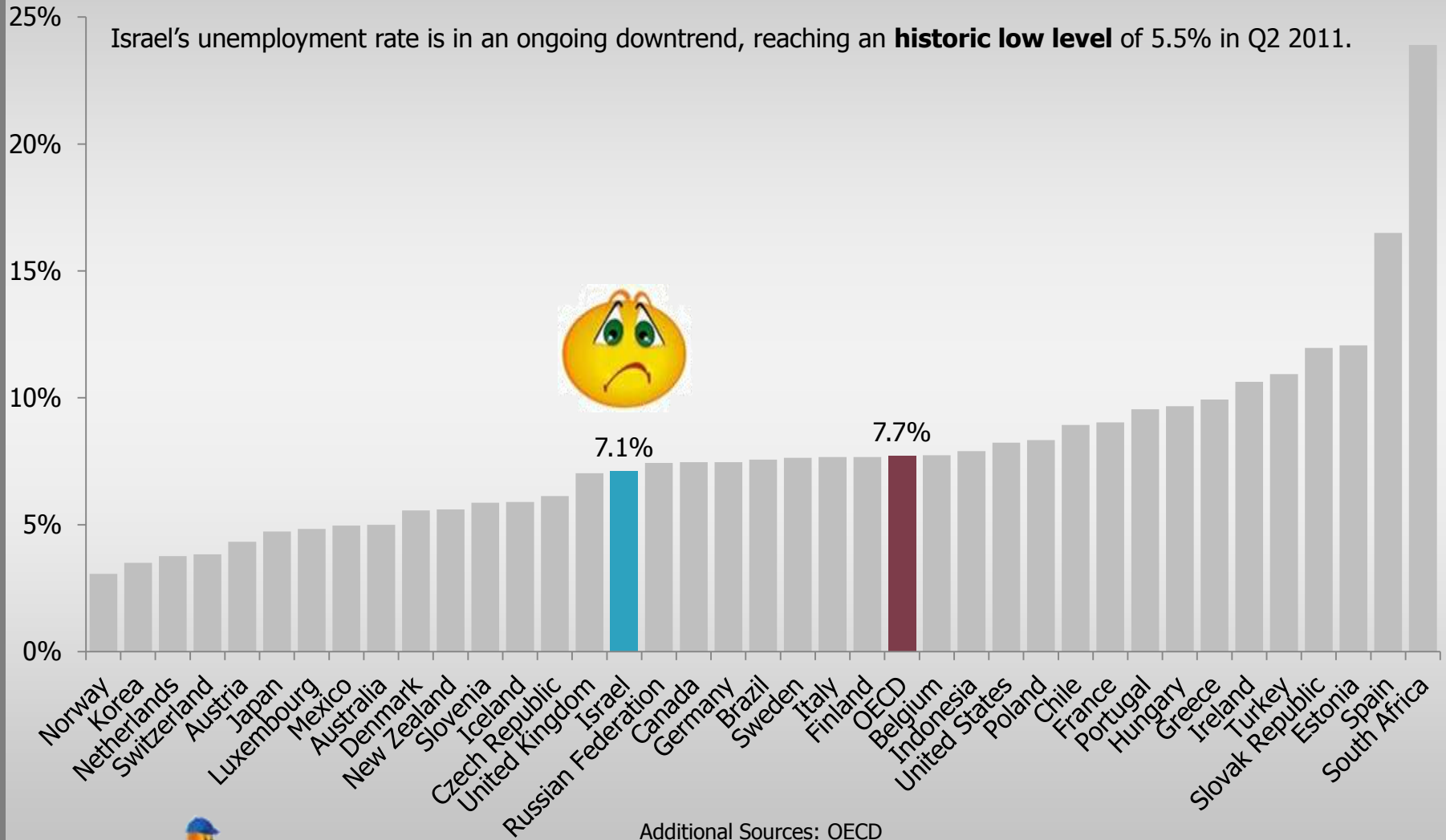

Additional Sources: OECD



Long-term unemployment

Persons unemployed for 12 months or more as a percentage of total unemployed

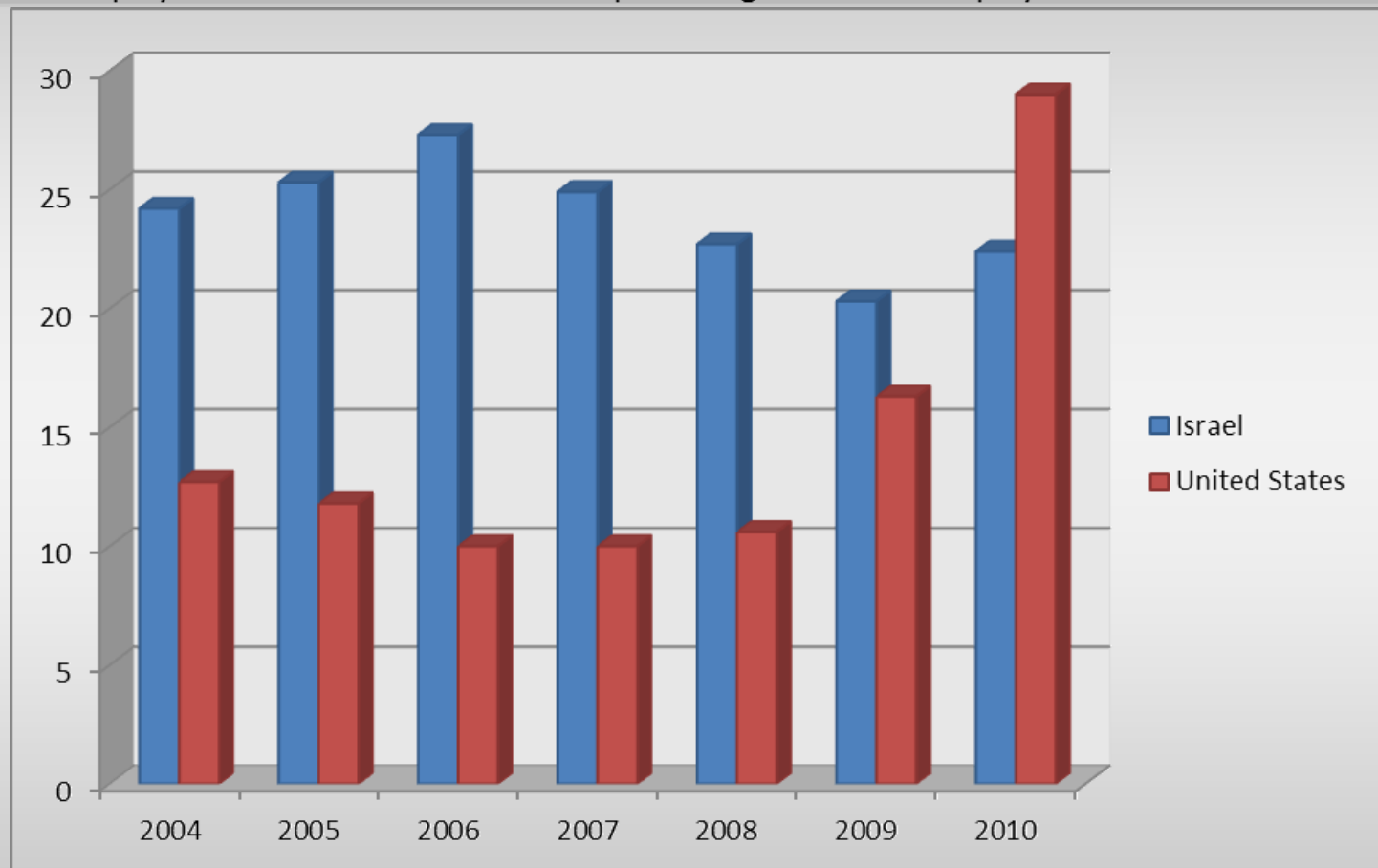

Unemployment and Participation

As % of total labor force

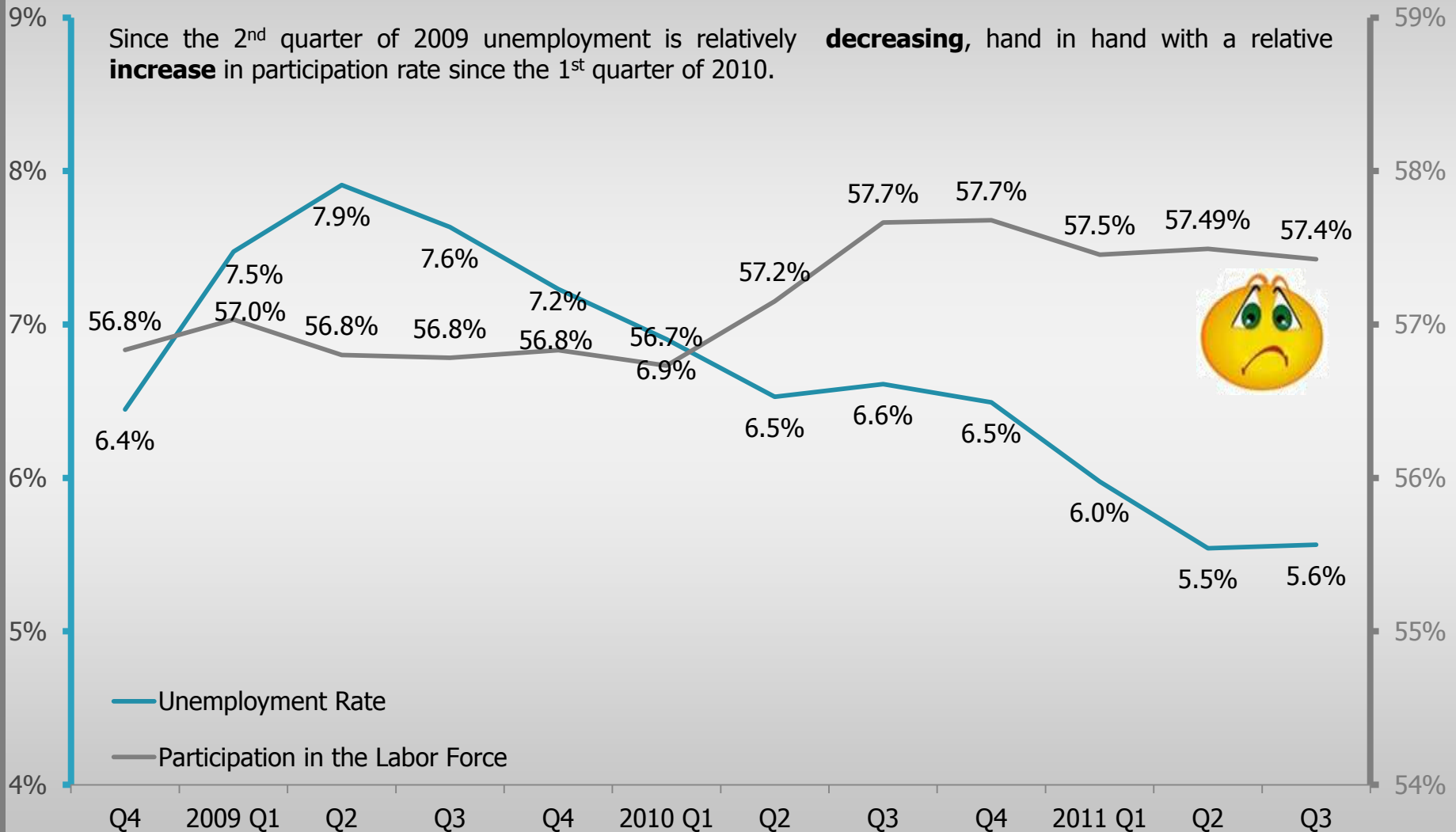



DOING BUSINESS

MEASURING BUSINESS REGULATIONS

- HOME
- DATA
- RANKINGS
- REPORTS
- METHODOLOGY
- RESEARCH
- BUSINESS REFORMS
- LAW LIBRARY

PRESS



Ease of Doing Business in

Israel

| 2012 Rank | 2011 Rank | 2010 Rank | 2009 Rank | Country/Region |
|-----------|-----------|-----------|-----------|--|
| 34 | 29 | 29 | 30 | Israel  |



Israel on IMD Rankings

IMD World Competitiveness Yearbook 2011

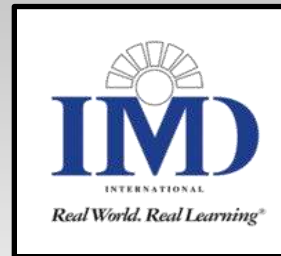

The Institute for Management Development ranked Israel **17th** out of 59 countries for 2011 (Israel was also ranked 17th in 2010)

| | |
|---------|------------------------|
| 100.000 | (2) HONG KONG 1 |
| 100.000 | (3) USA 1 |
| 98.557 | (1) SINGAPORE 3 |
| 94.063 | (6) SWEDEN 4 |
| 92.588 | (4) SWITZERLAND 5 |
| 92.011 | (8) TAIWAN 6 |
| 90.782 | (7) CANADA 7 |
| 90.219 | (15) QATAR 8 |
| 89.259 | (5) AUSTRALIA 9 |
| 87.824 | (16) GERMANY 10 |
| 86.475 | (11) LUXEMBOURG 11 |
| 86.418 | (13) DENMARK 12 |
| 86.313 | (9) NORWAY 13 |
| 85.707 | (12) NETHERLANDS 14 |
| 84.380 | (19) FINLAND 15 |
| 84.170 | (10) MALAYSIA 16 |
| 81.629 | (17) ISRAEL 17 |
| 81.619 | (14) AUSTRIA 18 |
| 81.100 | (18) CHINA MAINLAND 19 |
| 80.278 | (22) UNITED KINGDOM 20 |
| 79.799 | (20) NEW ZEALAND 21 |
| 78.499 | (23) KOREA 22 |
| 77.599 | (25) BELGIUM 23 |
| 77.101 | (21) IRELAND 24 |
| 76.827 | (28) CHILE 25 |
| 75.214 | (27) JAPAN 26 |
| 74.886 | (26) THAILAND 27 |
| 73.188 | UAE 28 |
| 71.394 | (24) FRANCE 29 |
| 70.990 | (29) CZECH REPUBLIC 30 |

Additional Sources: IMD World Competitiveness Yearbook 2011



Israel on IMD Rankings

IMD World Competitiveness Yearbook 2011

Information technology skills

| | | |
|----|---------|------|
| 1 | ISRAEL | 9.22 |
| 2 | ICELAND | 9.07 |
| 3 | DENMARK | 9.05 |
| 4 | SWEDEN | 8.93 |
| 5 | INDIA | 8.77 |
| 6 | FINLAND | 8.70 |
| 7 | NORWAY | 8.68 |
| 8 | USA | 8.63 |
| 9 | CANADA | 8.57 |
| 10 | TAIWAN | 8.47 |

Innovative capacity

| | | |
|----|-------------|------|
| 1 | USA | 8.24 |
| 2 | ISRAEL | 8.00 |
| 3 | SWITZERLAND | 7.88 |
| 4 | GERMANY | 7.60 |
| 5 | SWEDEN | 7.52 |
| 6 | TAIWAN | 7.30 |
| 7 | AUSTRIA | 7.24 |
| 8 | DENMARK | 7.21 |
| 9 | KOREA | 7.04 |
| 10 | JAPAN | 7.00 |

Additional Sources: IMD World Competitiveness Yearbook 2011

Flexible and adaptability

| | | |
|----|-------------|------|
| 1 | ISRAEL | 8.25 |
| 2 | HONG KONG | 8.24 |
| 3 | AUSTRALIA | 8.14 |
| 4 | BRAZIL | 8.08 |
| 5 | TAIWAN | 7.96 |
| 6 | TURKEY | 7.92 |
| 7 | IRELAND | 7.88 |
| 8 | PHILIPPINES | 7.88 |
| 9 | ICELAND | 7.64 |
| 10 | NEW ZEALAND | 7.63 |

Entrepreneurship

| | | |
|----|-----------|------|
| 1 | ISRAEL | 7.50 |
| 2 | MALAYSIA | 7.06 |
| 3 | COLOMBIA | 7.00 |
| 4 | TAIWAN | 6.98 |
| 5 | HONG KONG | 6.98 |
| 6 | KOREA | 6.87 |
| 7 | POLAND | 6.82 |
| 8 | BRAZIL | 6.70 |
| 9 | IRELAND | 6.69 |
| 10 | USA | 6.64 |



Israel on WEF Rankings

World Economic Forum Global Competitiveness Index 2011-2012

The World Economic Forum ranked Israel **22nd** out of 142 countries for 2011-2012

Additional Sources: World Economic Forum Global Competitiveness Index 2011-2012



| Country/Economy | GCI 2011-2012 | |
|----------------------|---------------|-------------|
| | Rank | Score |
| Switzerland | 1 | 5.74 |
| Singapore | 2 | 5.63 |
| Sweden | 3 | 5.61 |
| Finland | 4 | 5.47 |
| United States | 5 | 5.43 |
| Germany | 6 | 5.41 |
| Netherlands | 7 | 5.41 |
| Denmark | 8 | 5.40 |
| Japan | 9 | 5.40 |
| United Kingdom | 10 | 5.39 |
| Hong Kong SAR | 11 | 5.36 |
| Canada | 12 | 5.33 |
| Taiwan, China | 13 | 5.26 |
| Qatar | 14 | 5.24 |
| Belgium | 15 | 5.20 |
| Norway | 16 | 5.18 |
| Saudi Arabia | 17 | 5.17 |
| France | 18 | 5.14 |
| Austria | 19 | 5.14 |
| Australia | 20 | 5.11 |
| Malaysia | 21 | 5.08 |
| Israel | 22 | 5.07 |
| Luxembourg | 23 | 5.03 |
| Korea, Rep. | 24 | 5.02 |
| New Zealand | 25 | 4.93 |
| China | 26 | 4.90 |
| United Arab Emirates | 27 | 4.89 |

Israel on WEF Rankings

World Economic Forum Global Competitiveness Index 2011-2012

Government procurement of advanced technology products

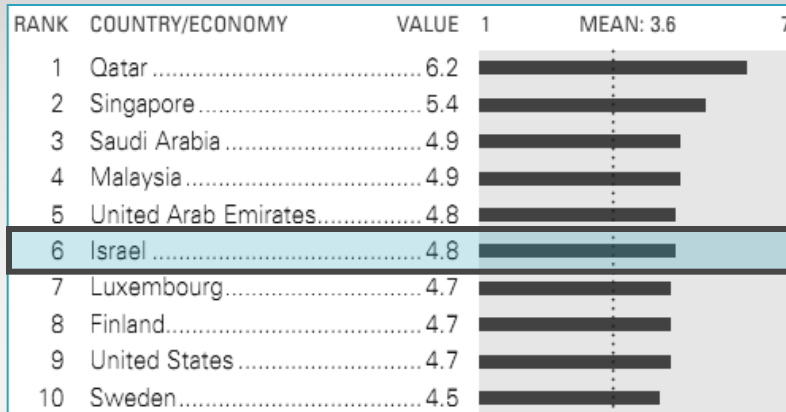

Capacity for innovation

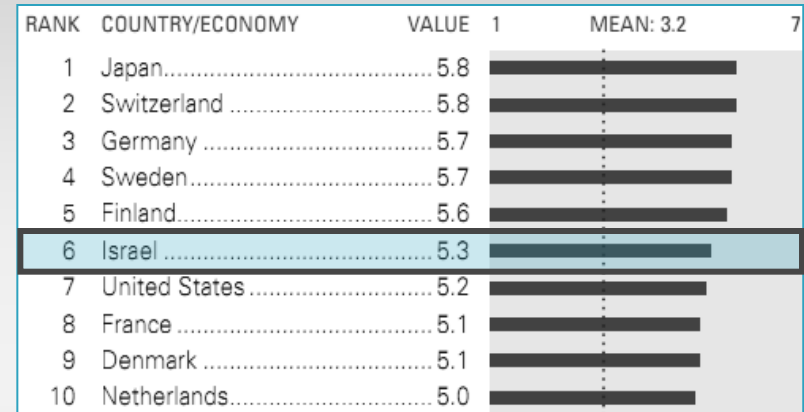

Firm-level technology absorption

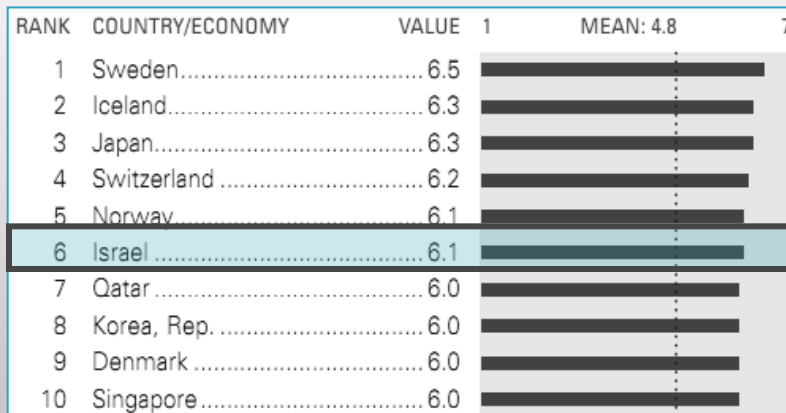

University-industry collaboration in R&D

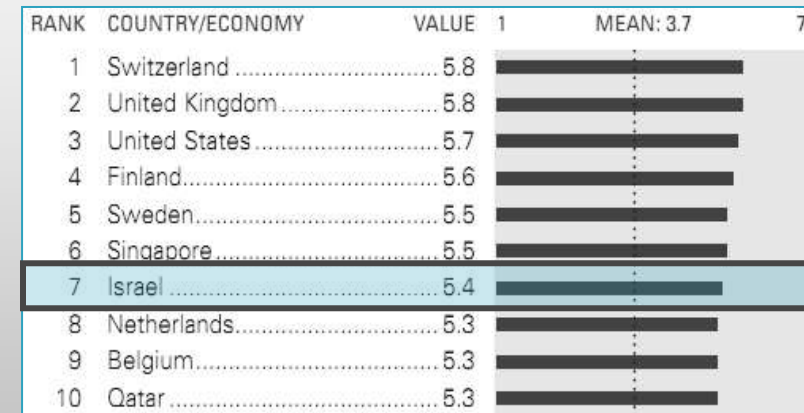

High Technology Industry Trends

מגמות תעשיות טכנולוגיה עלית
High - Technology Industries trends

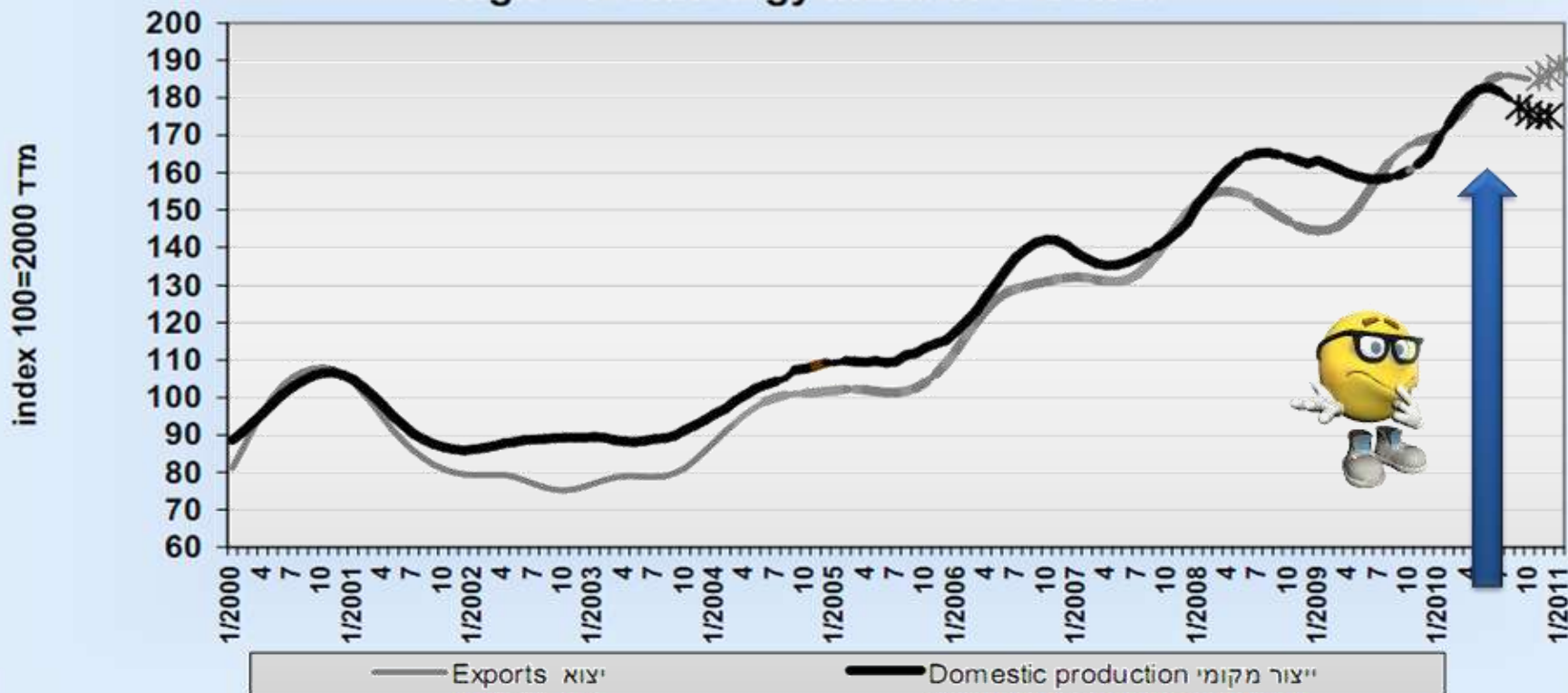

18.4 חלקם של ענפי ICT מכלל התוצר המקומי הגולמי, היצוא והמשרות

18.4 ICT Sector's Share of the Total Gross Domestic Product, Exports and Jobs

2004-2010

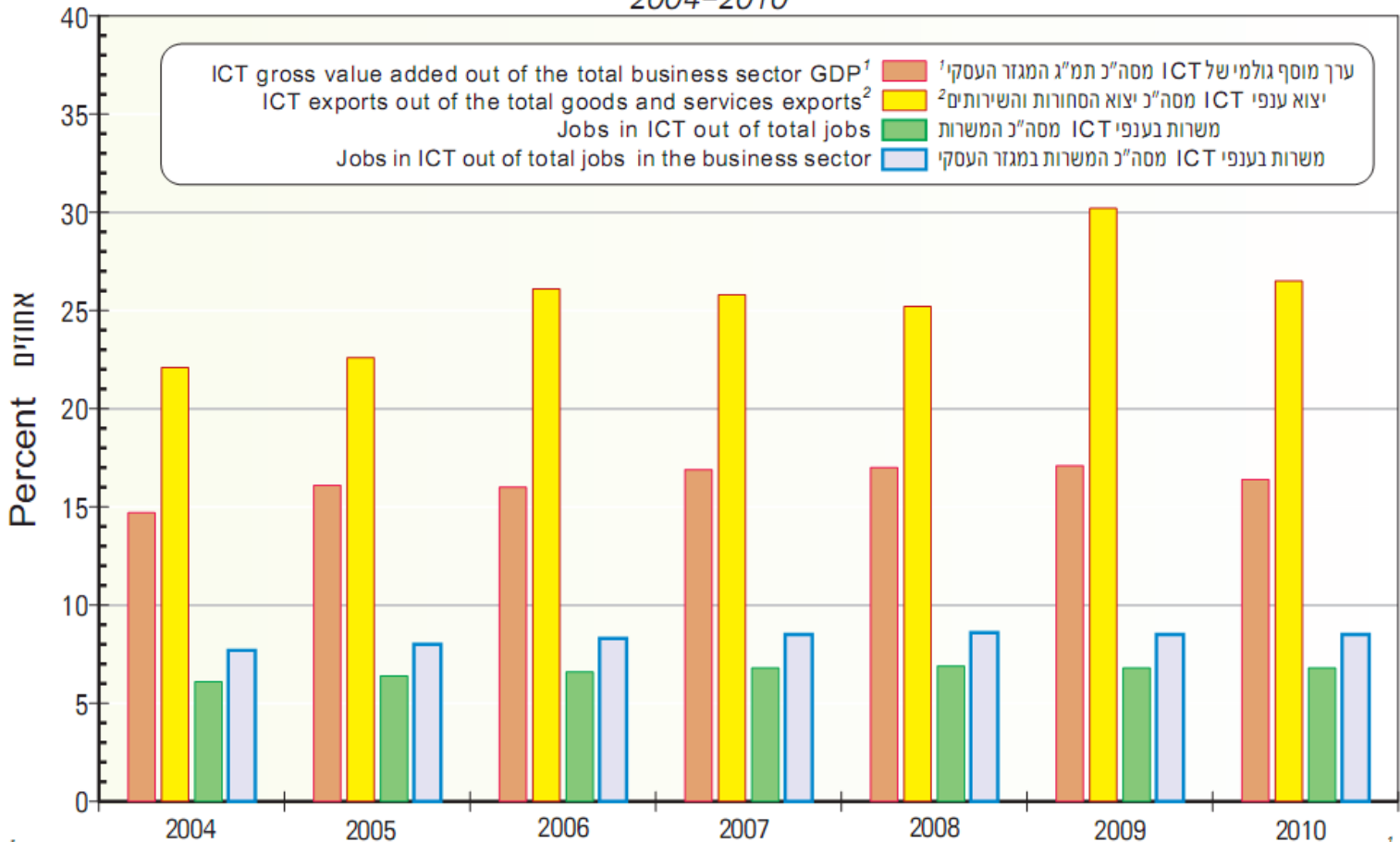

¹ Chained at 2005 prices.

² By classification of establishments, chained at 2005 prices.

¹ משורשר במחירי 2005.

² לפי סיווג החברות, משורשר במחירי 2005.

השכה המרכזית לסטטיסטיקה CENTRAL BUREAU OF STATISTICS

We rank VENDORS by
REVENUE
and
CLIENT MINDSHARE

All amounts in M \$ USD



סקר הערכת מגמות בעסקים: ינואר 2012

Business Tendency Survey: January 2012

תרשים 1. מאזן כללי: דצמבר 2010 - ינואר 2012

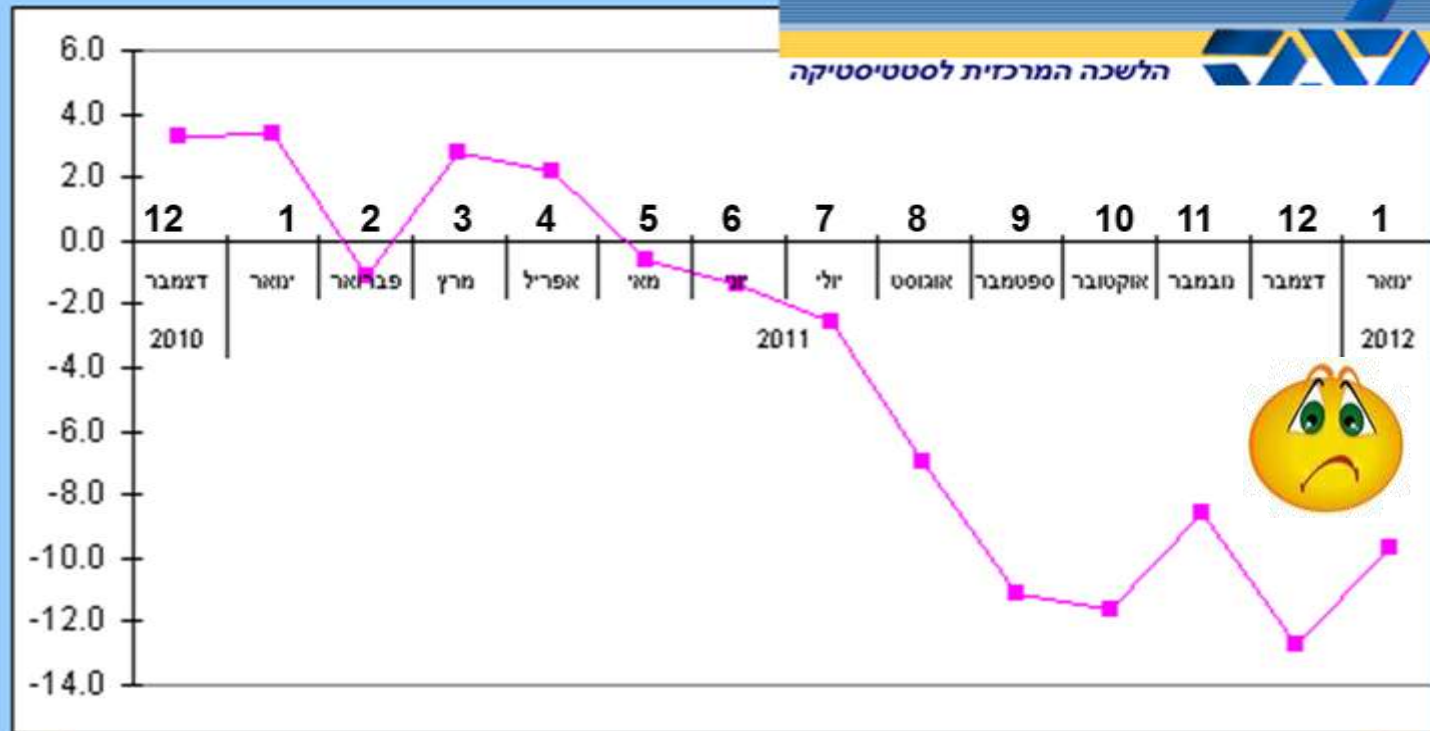

We rank VENDORS by
REVENUE
and
CLIENT MINDSHARE

All amounts in M \$ USD



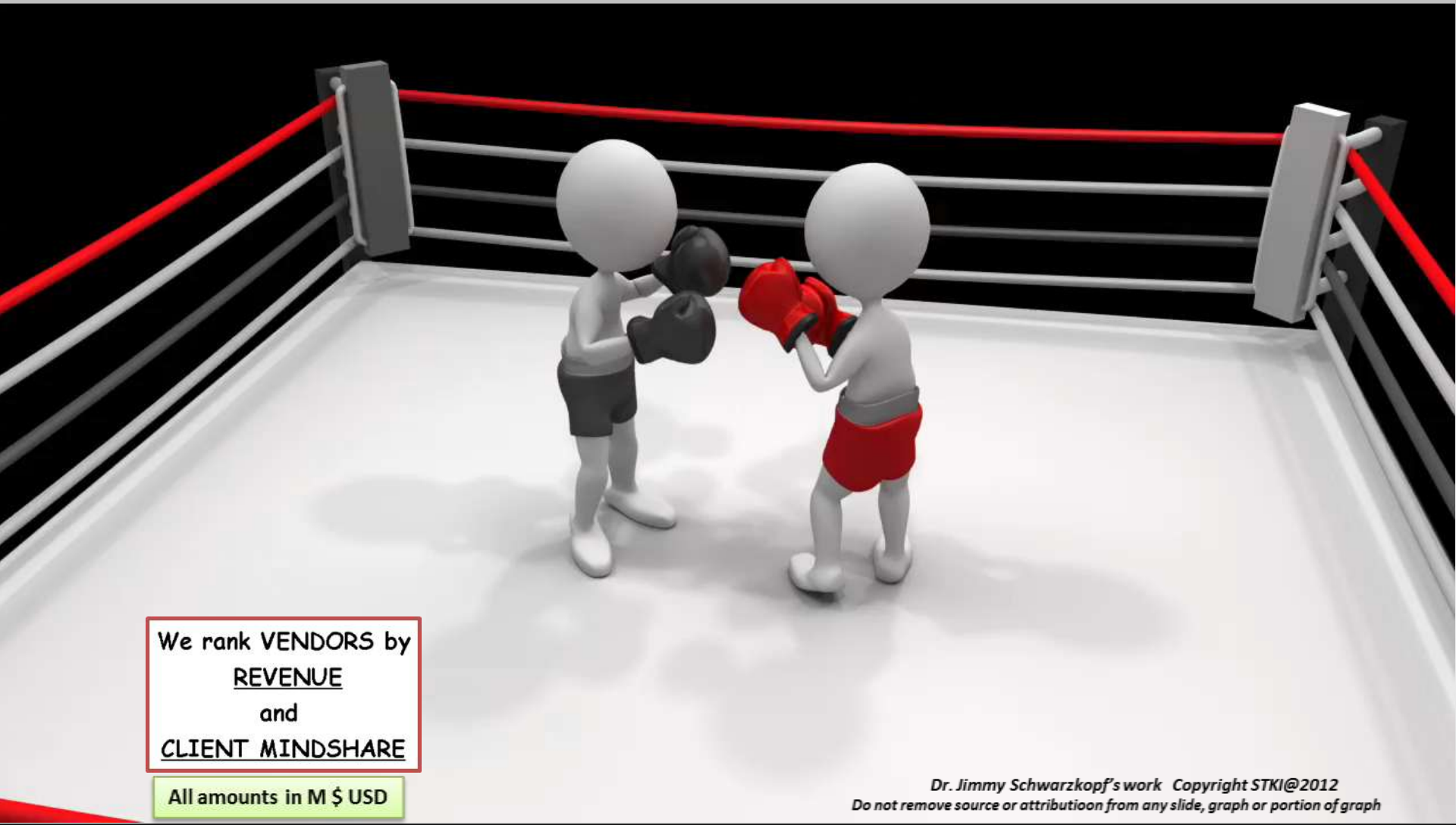

We rank VENDORS by
REVENUE
and
CLIENT MINDSHARE

All amounts in M \$ USD

*Dr. Jimmy Schwarzkopf's work Copyright STKI@2012
Do not remove source or attribution from any slide, graph or portion of graph*

It was the best of times, it was the worst of times.

IT Israel 2012: expectations from Bank Israel & STKI

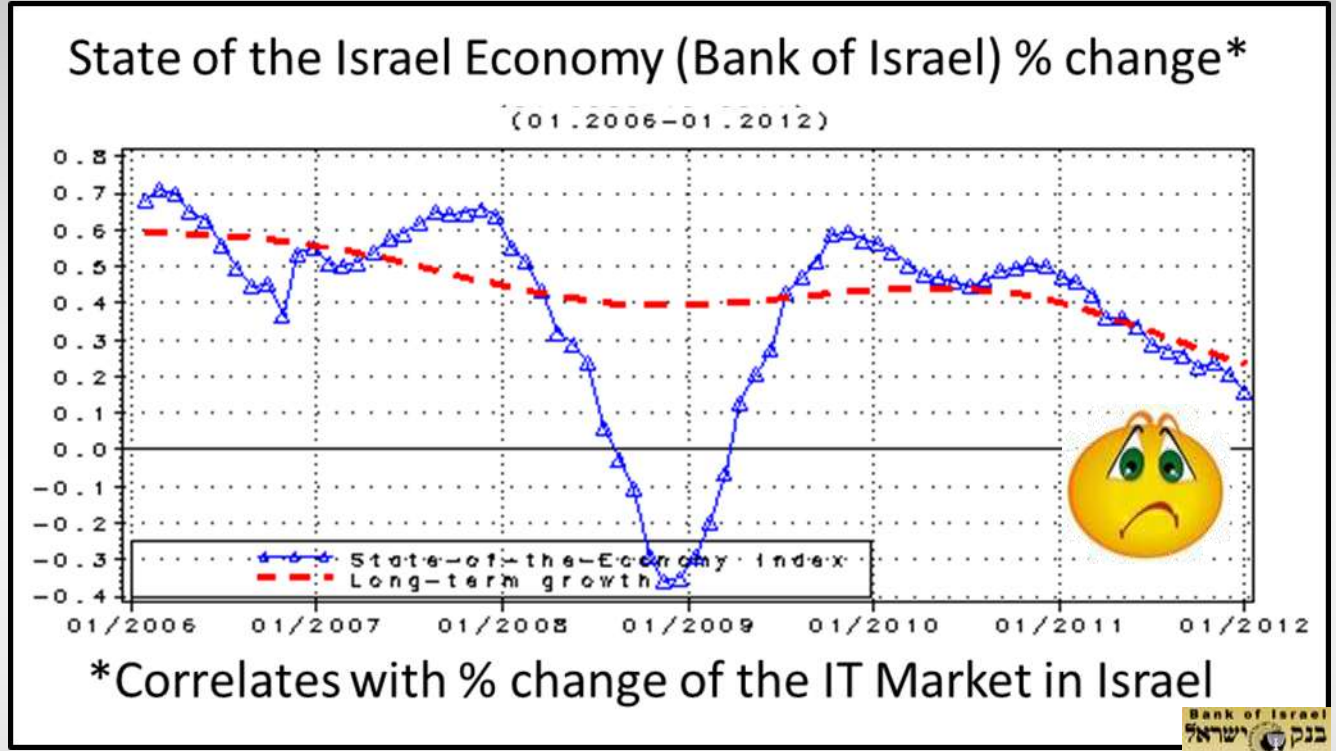

Israeli IT people : Wow! Unprecedented times!
*If you can keep your head when all about
 you are losing theirs...**

*Rudyard Kipling - 'If'

Number of "legal" entities paying taxes

Growth of 6.4 % in number of tax-paying companies 2010 to 2012



| number of employees | number of companies (2/2011) | number of companies (2/2012) | & of TOTAL | subtotals | | subtotals | | & of TOTAL | number of companies (2/2010) | number of employees | |
|--|------------------------------|------------------------------|------------|-----------|---------|-----------------------------------|---------|------------|------------------------------|---------------------|--------|
| 251+ | 1,348 | 1,416 | 0.59% | 3,814 | | 3,298 | | 0.10% | 236 | 1001+ | |
| 101-250 | 2,384 | 2,398 | 1.00% | | | | | 0.18% | 419 | 401-1000 | |
| 51-100 | 3,871 | 4,040 | 1.64% | | | | | 0.64% | 1,470 | 151-400 | |
| 10-50 | 31,720 | 32,488 | 13.43% | 36,528 | 236,463 | 225,824 | 56,603 | 6.28% | 14,419 | 21-100 | |
| up to 9 | 196,802 | 199,935 | 83.35% | 199,935 | | | 169,221 | 73.71% | 169,221 | 18.38% | 42,184 |
| TOTAL | 240,277 | | | | | 441 | | 0.15% | 335 | municipalities | |
| | | | | | | | | 0.05% | 106 | government | |
| | | | | | | 225,824 | | | | TOTAL | |
| ACCORDING TO BITUACH LEUMI 2/2011 & 2/2012 | | | | | | ACCORDING TO BITUACH LEUMI 2/2010 | | | | | |

We rank VENDORS by
REVENUE
and
CLIENT MINDSHARE

All amounts in M \$ USD



BUDGETS (opex/capex): include **some** internal expenses

| industry | Market size | % total | % total | Market size | industry |
|------------------|---|--------------------|---------|---|-------------------------|
| government | 1,350 | 19.88% | 33.87% | 2,300 | public |
| security | 400 | 5.89% | | | |
| education | 250 | 3.68% | | | |
| health | 300 | 4.42% | | | |
| utilities | 280 | 4.12% | 8.54% | 580 | utilities/ transport |
| transport | 300 | 4.42% | | | |
| banks | 900 | 13.25% | 21.35% | 1,450 | financial |
| insurance | 350 | 5.15% | | | |
| fin other | 200 | 2.95% | | | |
| manuf | 820 | 12.08% | 15.02% | 1,020 | manuf/ retail |
| retail | 200 | 2.95% | | | |
| high tech | 650 | 9.57% | 12.37% | 840 | high tech/ IT |
| IT local vendors | 190 | 2.80% | | | |
| telecomm | 260 | 3.83% | 5.15% | 350 | Telecomm/ media |
| media | 90 | 1.33% | | | |
| SMB | 250 | 3.68% | 3.68% | 250 | SMB |
| TOTAL |  | 6,790 M USD | |  | TOTAL |

We rank VENDORS by
REVENUE
and
CLIENT MINDSHARE

All amounts in M \$ USD



Why does the "STKI Market size" change?

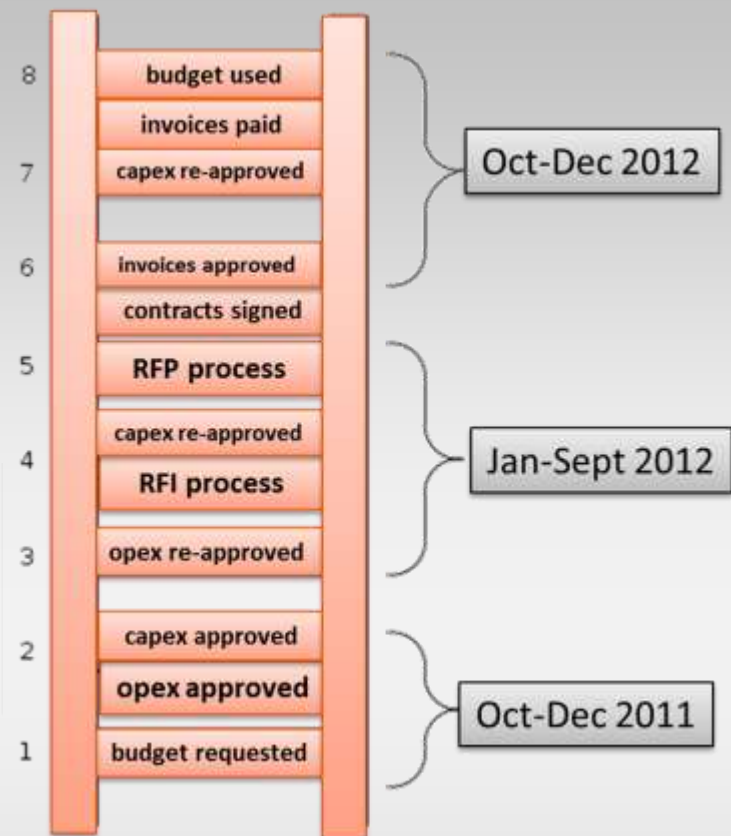
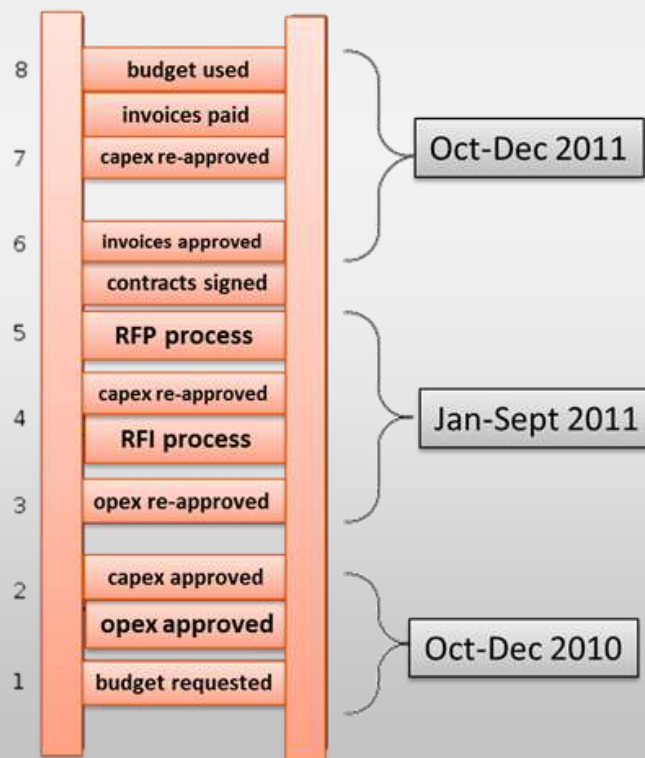

IT Markets in Israel

| | 2007 | | 2008 | | 2009 | | 2010 |
|----------------------|-----------|---------|-----------|--------|-----------|--------|-----------|
| HARDWARE | 1,750,000 | -27.14% | 1,275,000 | -3.53% | 1,230,000 | 22.20% | 1,503,000 |
| SOFTWARE | 732,150 | 14.73% | 840,000 | 10.19% | 925,620 | 21.22% | 1,122,000 |
| VALUE ADDED SERVICES | 2,320,000 | 13.37% | 2,630,200 | -8.94% | 2,395,000 | 11.15% | 2,662,000 |
| TOTAL | 4,802,150 | -1.19% | 4,745,200 | -4.10% | 4,550,620 | 16.18% | 5,287,000 |

| | 2010 | | 2011 | | 2012 | | 2013 |
|----------------------|-----------|--------|-----------|-------|-----------|--------|-----------|
| HARDWARE | 1,503,000 | 13.04% | 1,699,000 | 1.82% | 1,730,000 | 3.35% | 1,788,000 |
| SOFTWARE | 1,122,000 | 8.84% | 1,221,200 | 5.49% | 1,288,200 | 7.90% | 1,390,000 |
| VALUE ADDED SERVICES | 2,662,000 | 12.58% | 2,997,000 | 4.07% | 3,119,000 | 11.61% | 3,481,000 |
| TOTAL | 5,287,000 | 11.92% | 5,917,200 | 3.72% | 6,137,200 | 8.50% | 6,659,000 |

Forecasted

We rank VENDORS by
REVENUE
and
CLIENT MINDSHARE

All amounts in M \$ USD



IT Market (% change) in Israel (3/2012)

| | IT budget change (spent data) | | | | *forecasted | |
|----------------------------|-------------------------------|--------|---------|---------|-------------|---------|
| | 2007-8 | 2008-9 | 2009-10 | 2010-11 | 2011-12 | 2012-13 |
| HARDWARE | -27.14% | -3.53% | 22.20% | 13.04% | 1.82% | 3.35% |
| SOFTWARE | 14.73% | 10.19% | 21.22% | 8.84% | 5.49% | 7.90% |
| VALUE ADDED SERVICES | 13.37% | -8.94% | 11.15% | 12.58% | 4.07% | 11.61% |
| total | -1.19% | -4.10% | 16.18% | 11.92% | 3.72% | 8.50% |

We rank VENDORS by
REVENUE
and
CLIENT MINDSHARE

All amounts in M \$ USD



Percent change per IT Market

Projects are difficult to stop but also to start

Software sales are not influenced by economic turns

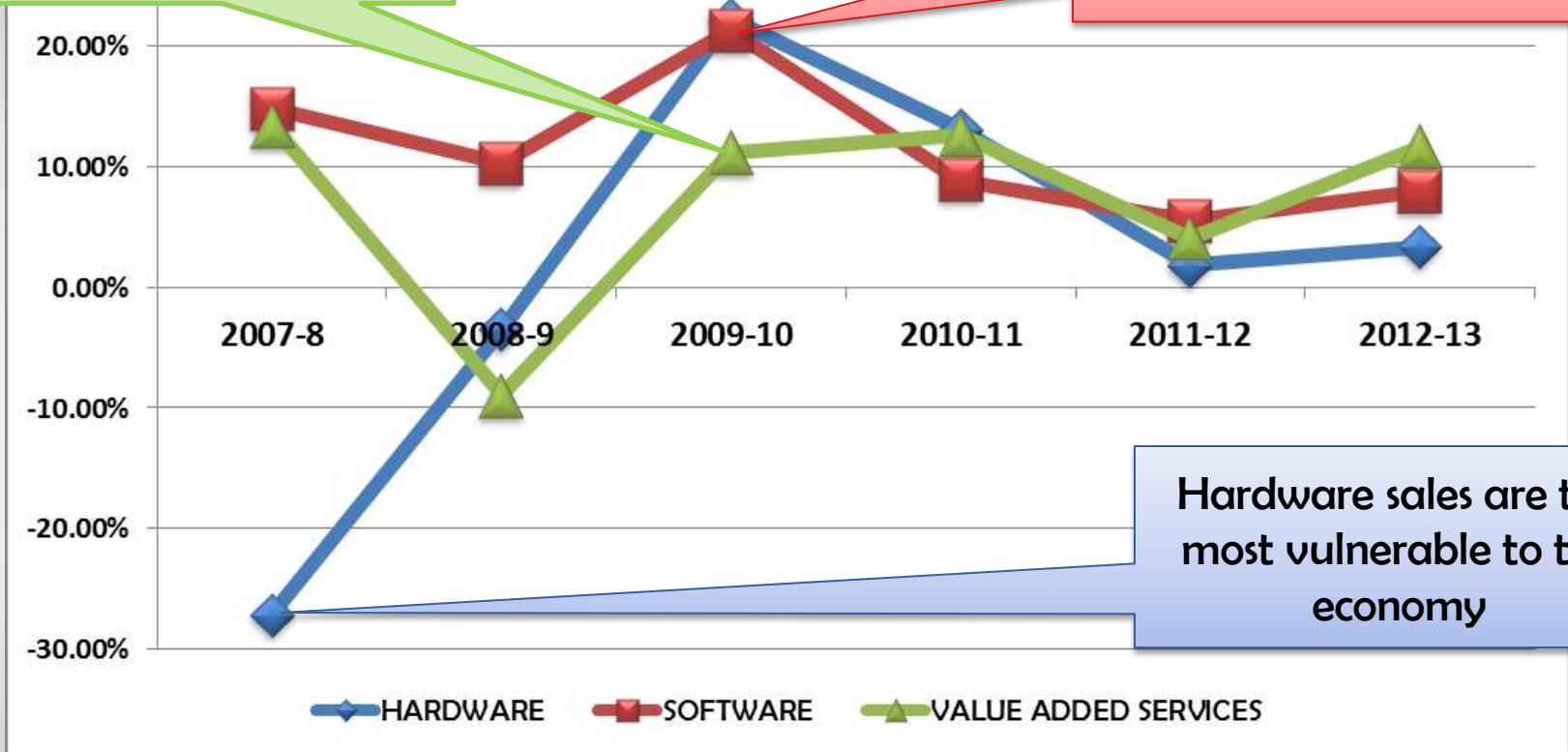

Hardware sales are the most vulnerable to the economy

We rank VENDORS by
REVENUE
and
CLIENT MINDSHARE

All amounts in M \$ USD



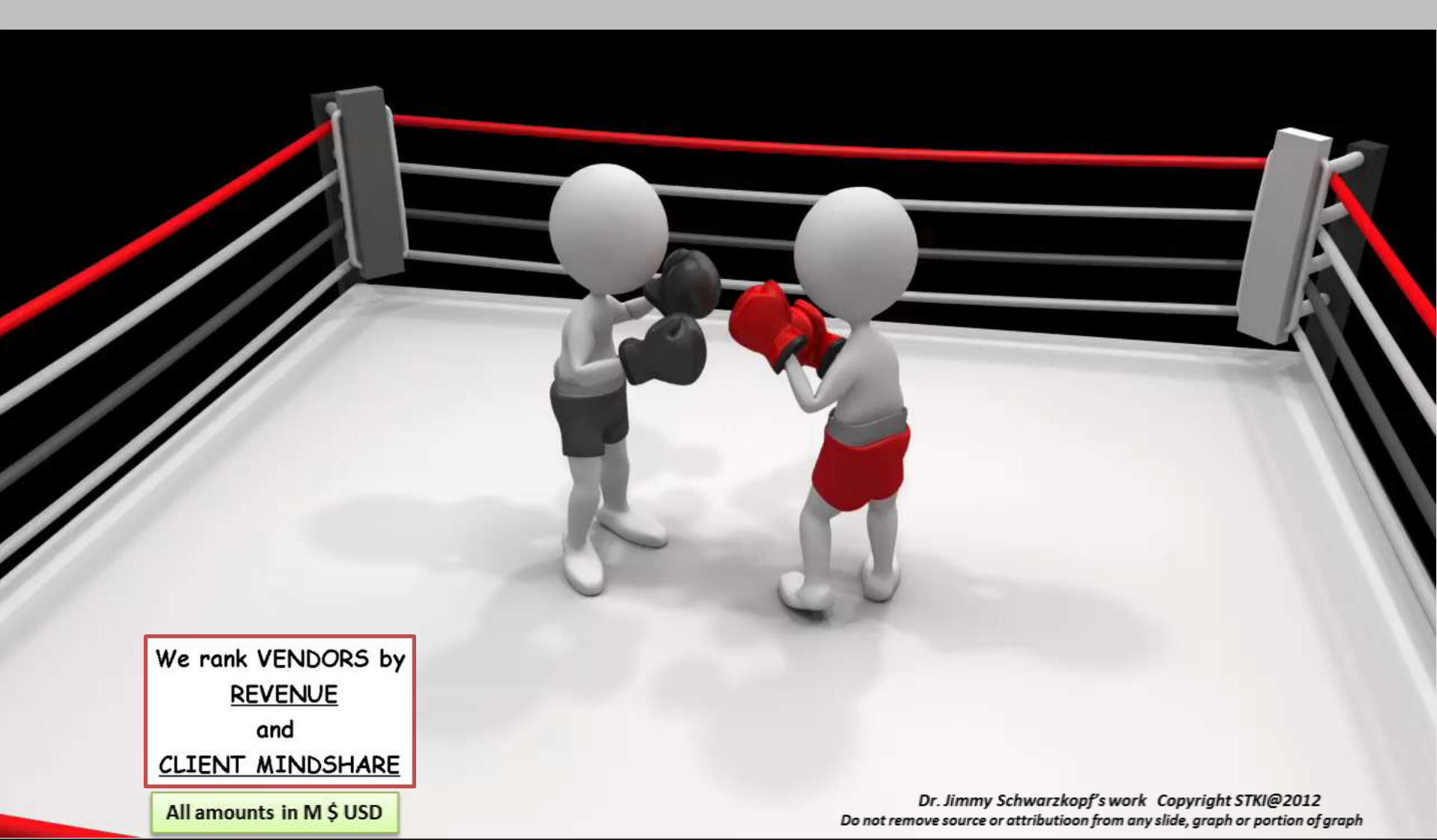

We rank VENDORS by
REVENUE
and
CLIENT MINDSHARE

All amounts in M \$ USD

*Dr. Jimmy Schwarzkopf's work Copyright STKI@2012
Do not remove source or attribution from any slide, graph or portion of graph*



Total IT Market : TIERS

2012 Israel IT Market

*Dr. Jimmy Schwarzkopf's work Copyright STKI@2012
Do not remove source or attribution from any slide, graph or portion of graph*

THE GREAT

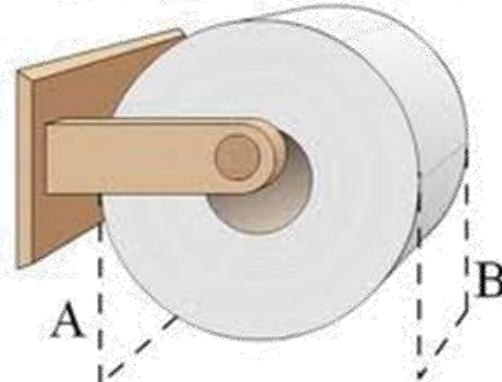

DEBATE

***"It is not enough
that I should
succeed, others
must fail "-
Gore Vidal***

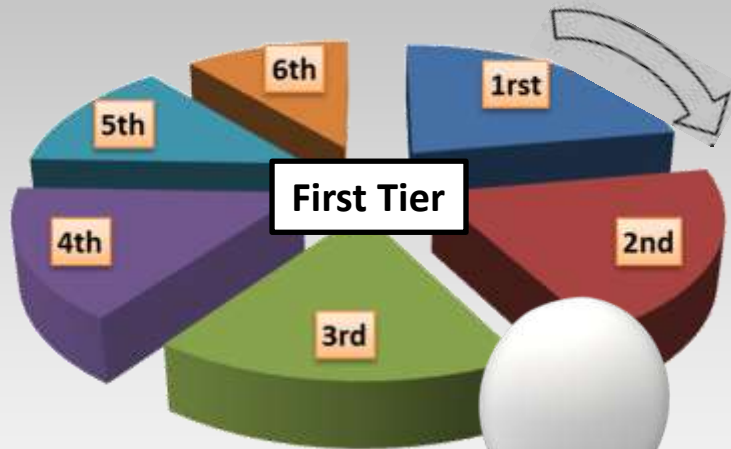

SECOND TIER

| |
|---|
| 1 |
| 2 |
| 3 |
| 4 |
| 4 |
| 6 |
| : |
| N |

We rank VENDORS by
REVENUE
and
CLIENT MINDSHARE

All amounts in M \$ USD



✳ Manufacturer (vendor)



Value Added Resellers
“VAR or Partners”
 are incorporated into
 STKI’s “TIERS” as is
 the original product
 developer. Both sell
 into the Israeli Market.

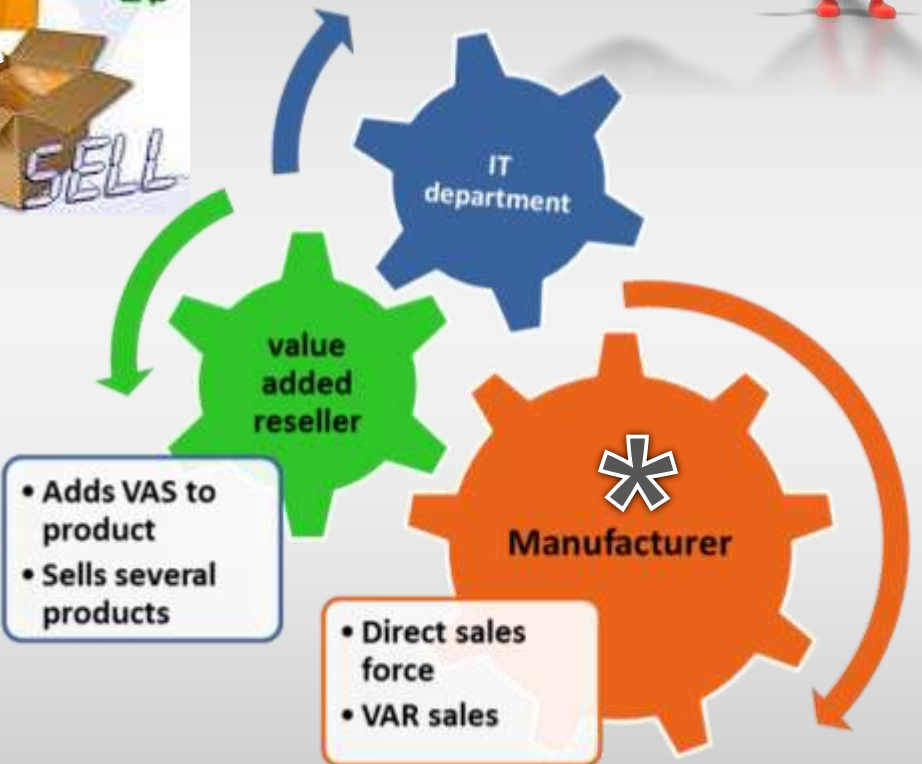
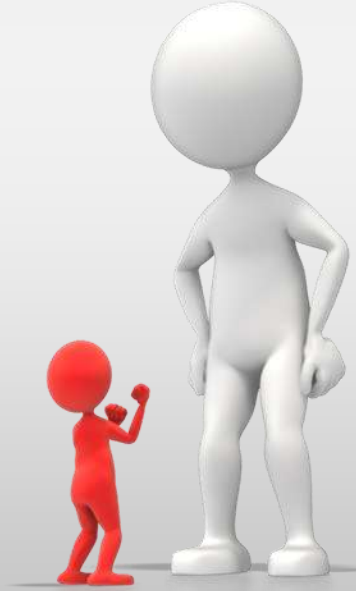

Biggest IT Vendors in Israel

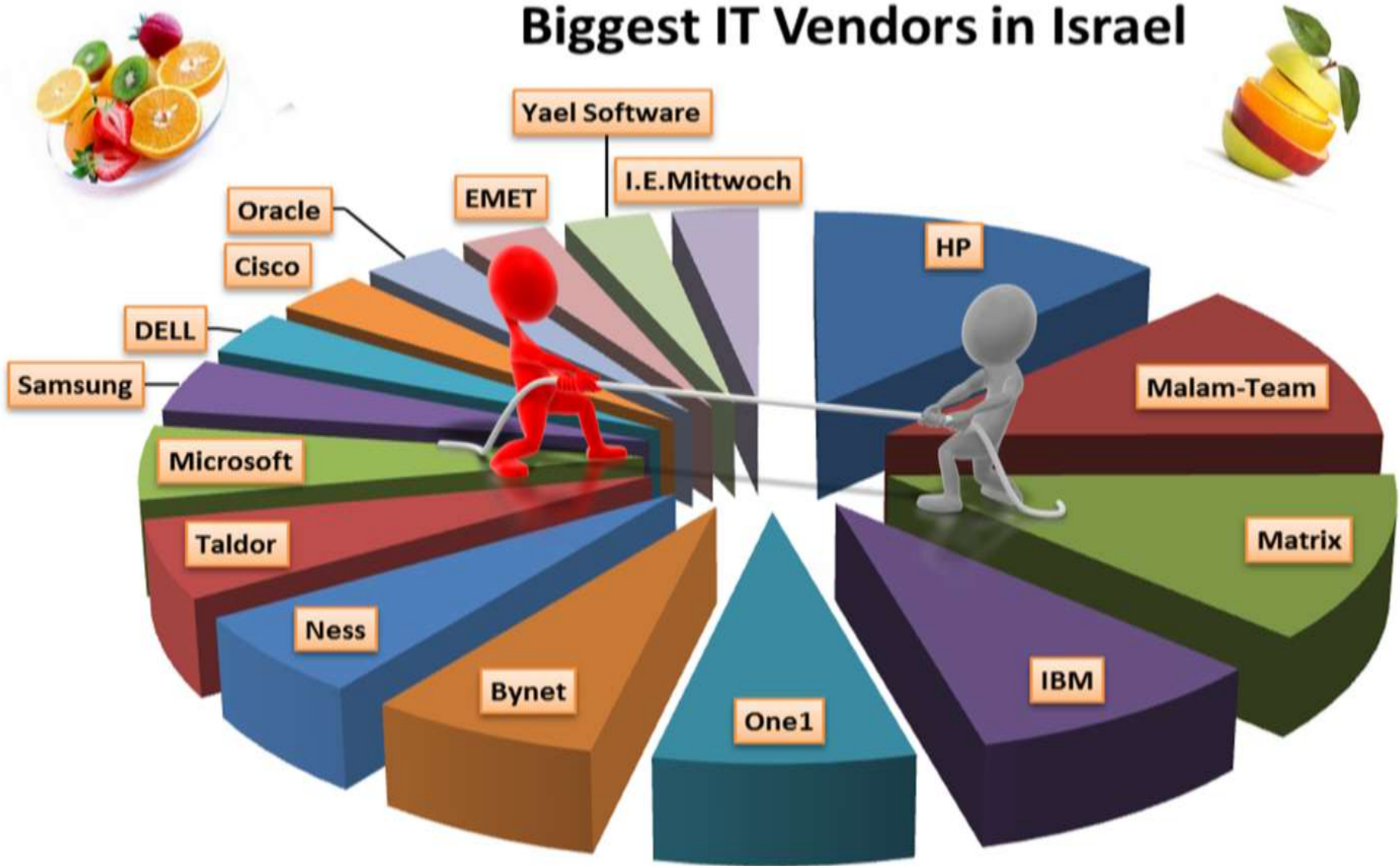

We rank VENDORS by
REVENUE
and
CLIENT MINDSHARE

All amounts in M \$ USD



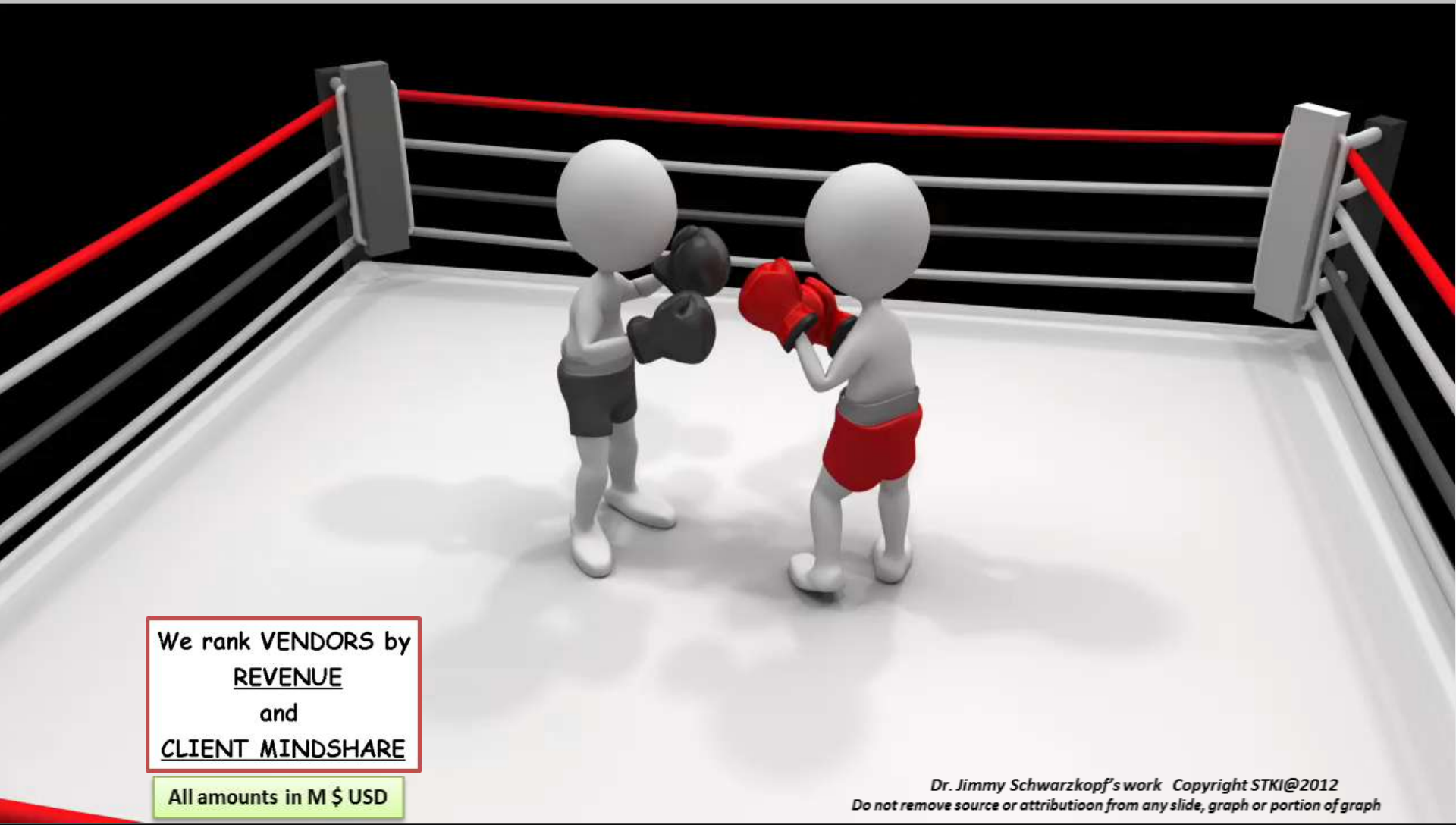

We rank VENDORS by
REVENUE
and
CLIENT MINDSHARE

All amounts in M \$ USD

*Dr. Jimmy Schwarzkopf's work Copyright STKI@2012
Do not remove source or attribution from any slide, graph or portion of graph*

Israel: IT Hardware Total Market 2011-2013



| 2011 | | 2012 | | 2013 |
|---------|-------|---------|-------|---------|
| 1,699.0 | 1.82% | 1,730.0 | 3.35% | 1,788.0 |

We rank VENDORS by
REVENUE
and
CLIENT MINDSHARE

All amounts in M \$ USD



Top Hardware Vendors

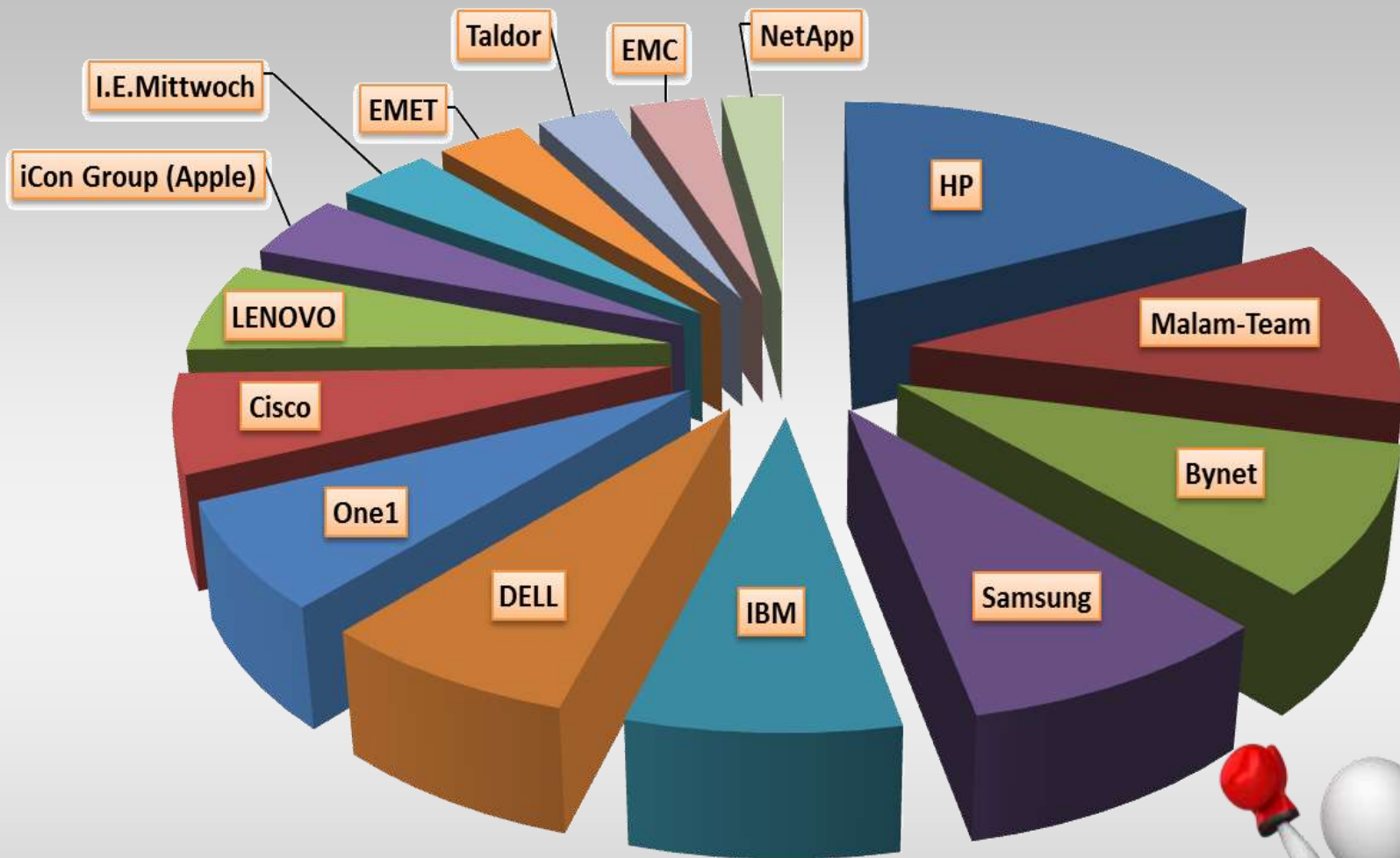

We rank VENDORS by
REVENUE
and
CLIENT MINDSHARE

All amounts in M \$ USD



Server Market



| 2011 | | 2012 | | 2013 | | | |
|--------------|--------------|--------------|--------------|--------------|------------------|------|---------|
| 110.0 | 4.55% | 115.0 | 4.35% | 120.0 | servers | x386 | servers |
| 130.0 | 15.38% | 150.0 | 6.67% | 160.0 | blades | | |
| 60.0 | -16.67% | 50.0 | -10.00% | 45.0 | legacy (non X86) | | |
| 12.0 | 50.00% | 18.0 | 38.89% | 25.0 | DBMS Appliances | | |
| 312.0 | 6.73% | 333.0 | 5.11% | 350.0 | totals | | |

We rank VENDORS by
REVENUE
 and
CLIENT MINDSHARE

All amounts in M \$ USD



Comparison Servers 2012

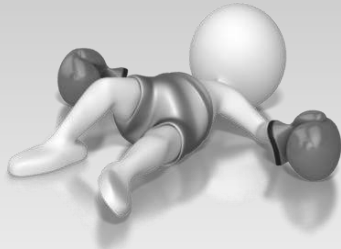

Rack-mounted servers

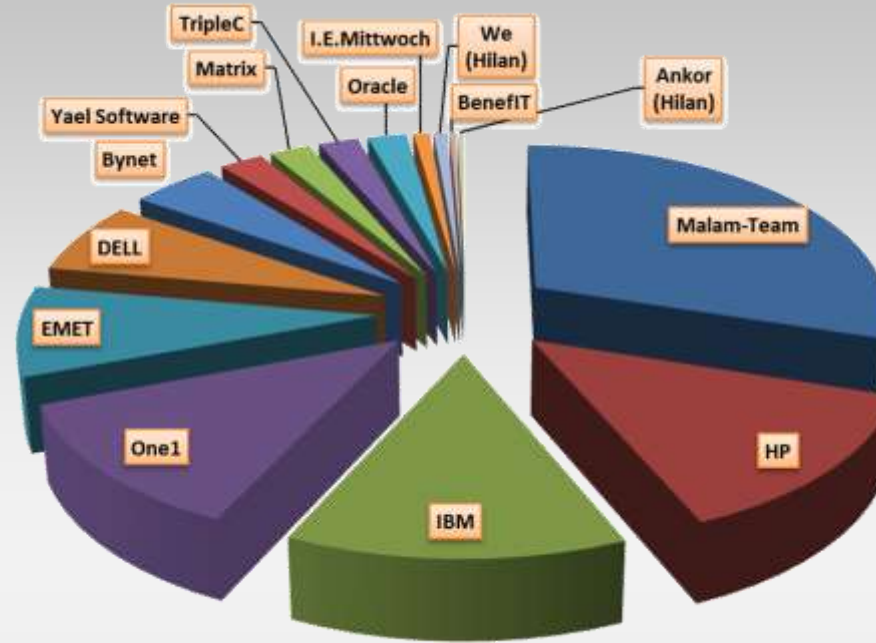

Blade Servers

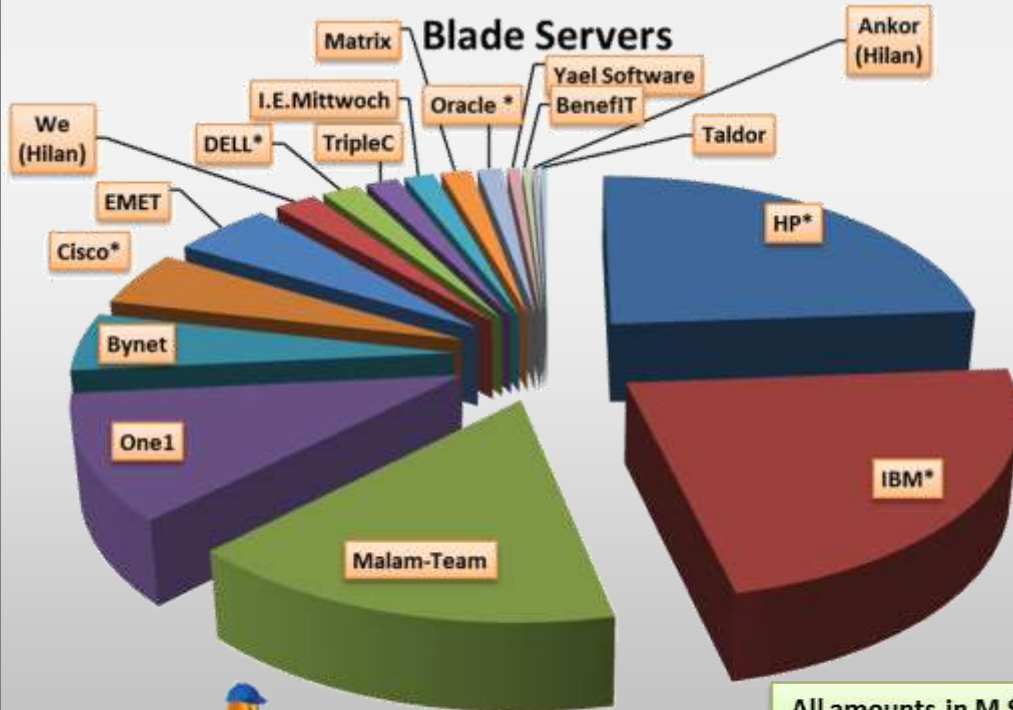

All amounts in M \$ USD



Client Market



| 2011 | | 2012 | | 2013 | | |
|-------|---------|-------|---------|-------|------------------|---------|
| 205.0 | -11.22% | 182.0 | -3.85% | 175.0 | notebooks | Clients |
| 152.0 | -13.16% | 132.0 | -16.67% | 110.0 | desk | |
| 7.0 | -28.57% | 5.0 | 40.00% | 7.0 | thin clients | |
| 100.0 | 20.00% | 120.0 | 25.00% | 150.0 | mobility/tablets | |
| 464.0 | -5.39% | 439.0 | 0.68% | 442.0 | totals | |

We rank VENDORS by
REVENUE
 and
CLIENT MINDSHARE

All amounts in M \$ USD



Israel (expected end 2012):



iPads: 400,000
iPhones: 1,500,000



Tablets: 100,000
Phones: 800,000



By the end of 2012
W8 will be a
REAL COMPETITOR

Wintel: Q42011 compared to Q42010
Desktop PCs: -25% Notebooks: -35%

Comparison Clients 2012



Desktop Manufacturers

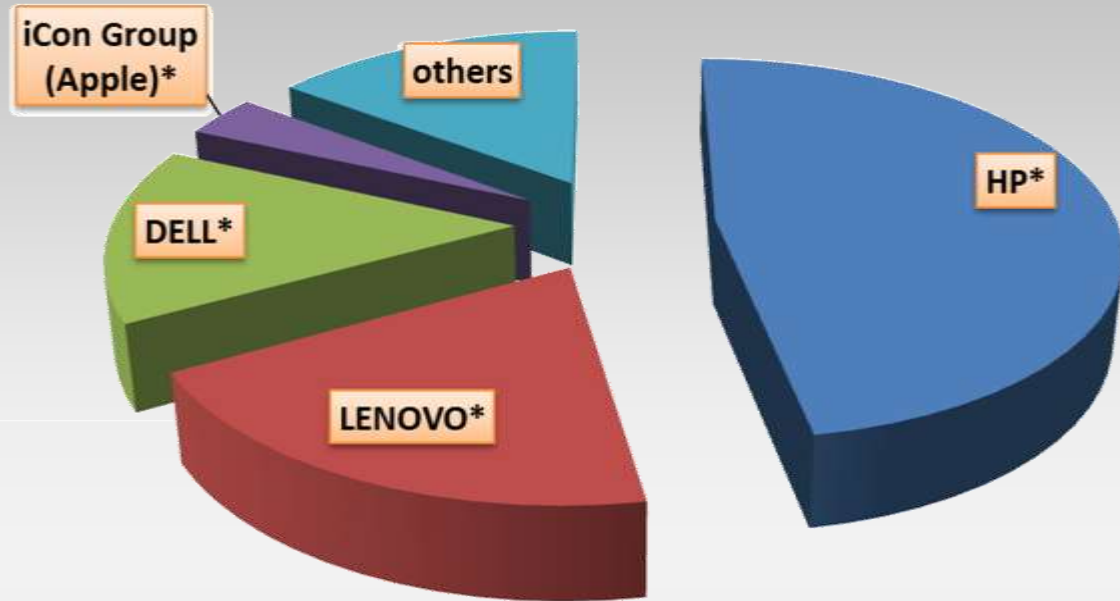

Notebook Manufacturers

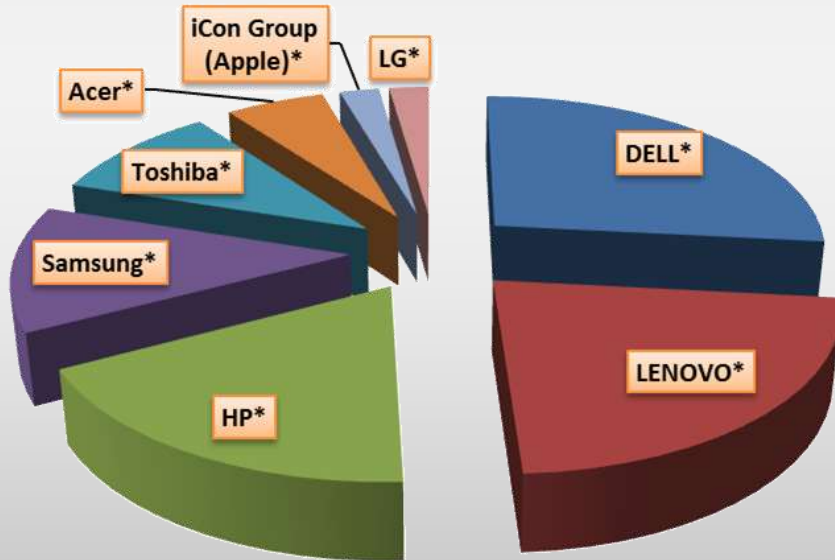

All amounts in M \$ USD

Dr. Jimmy Schwarzkopf's work Copyright STKI@2012
Do not remove source or attribution from any slide, graph or portion of graph

We rank VENDORS by
REVENUE
and
CLIENT MINDSHARE

Storage Market



| 2011 | | 2012 | | 2013 | | |
|-------|---------|-------|---------|-------|--------|---------|
| 165.0 | 5.45% | 174.0 | 6.90% | 186.0 | disks | storage |
| 15.0 | -33.33% | 10.0 | -20.00% | 8.0 | tapes | |
| 180.0 | 2.22% | 184.0 | 5.43% | 194.0 | totals | |

We rank VENDORS by
REVENUE
 and
CLIENT MINDSHARE

All amounts in M \$ USD



Comparison Storage 2012

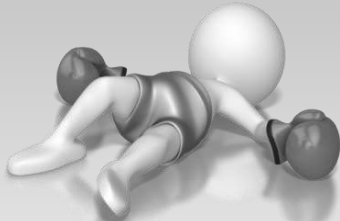

VTL backup appliances

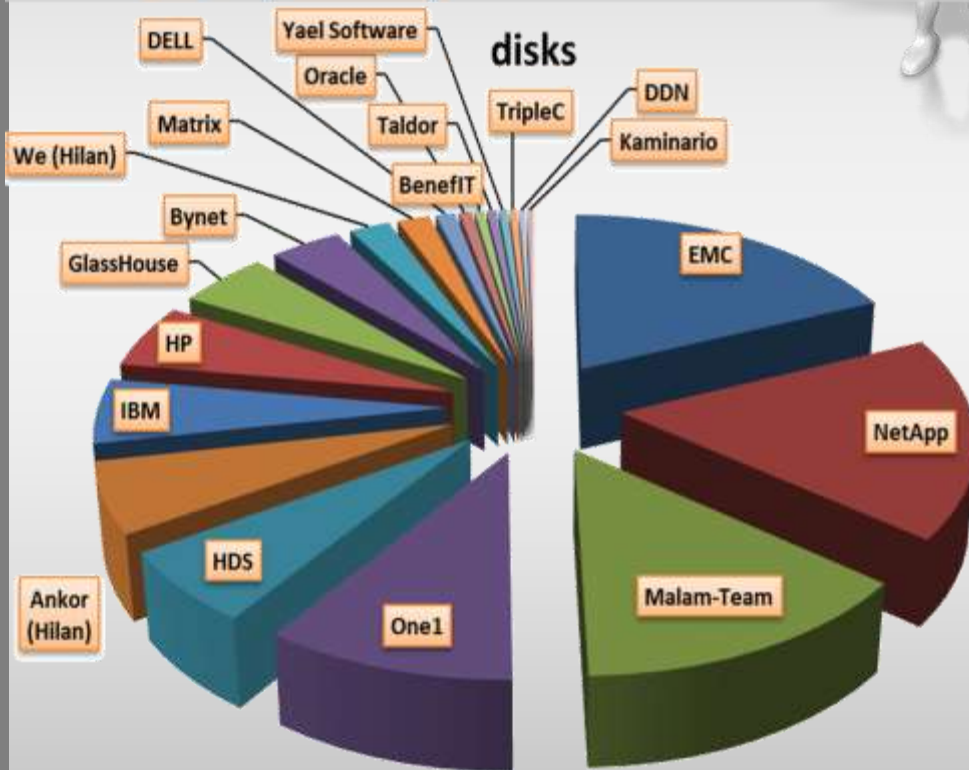
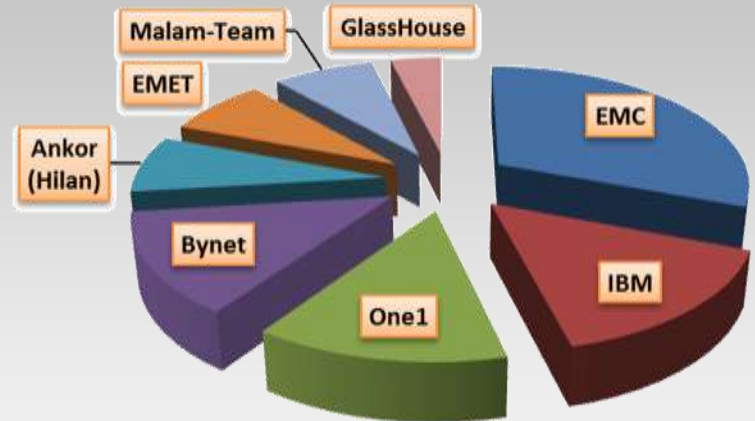

Tape Libraries*

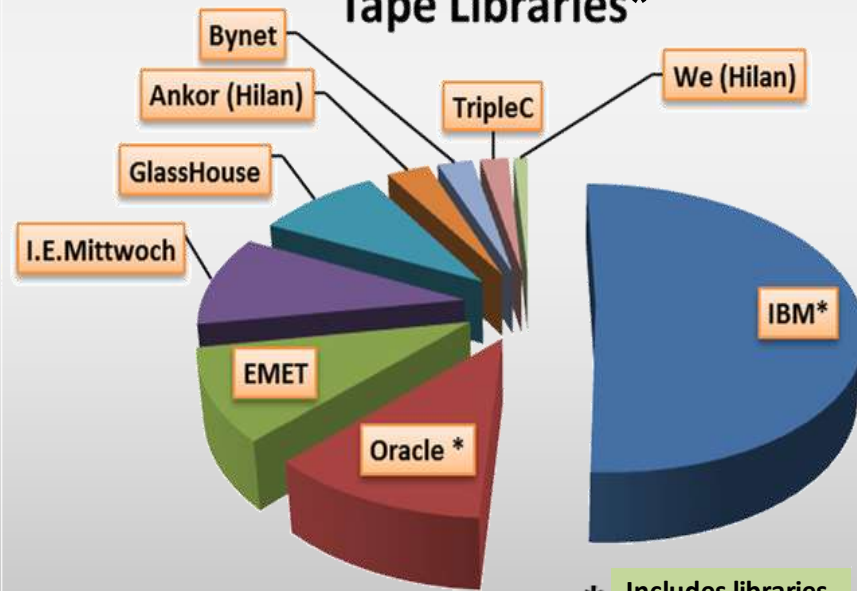

* Includes libraries & supplies

All amounts in M \$ USD

We rank VENDORS by
REVENUE
and
CLIENT MINDSHARE

Networking Market



| 2011 | | 2012 | | 2013 | | |
|-------|--------|-------|--------|-------|----------------------------|------------|
| 192.0 | 9.38% | 210.0 | 6.19% | 223.0 | enterprise networking | networking |
| 52.0 | 11.54% | 58.0 | 10.34% | 64.0 | security equipment | |
| 40.0 | 12.50% | 45.0 | 11.11% | 50.0 | VoIP/call center equipment | |
| 284.0 | 10.21% | 313.0 | 7.67% | 337.0 | totals | |

We rank VENDORS by
REVENUE
 and
CLIENT MINDSHARE

All amounts in M \$ USD



Comparison Enterprise Networking 2012

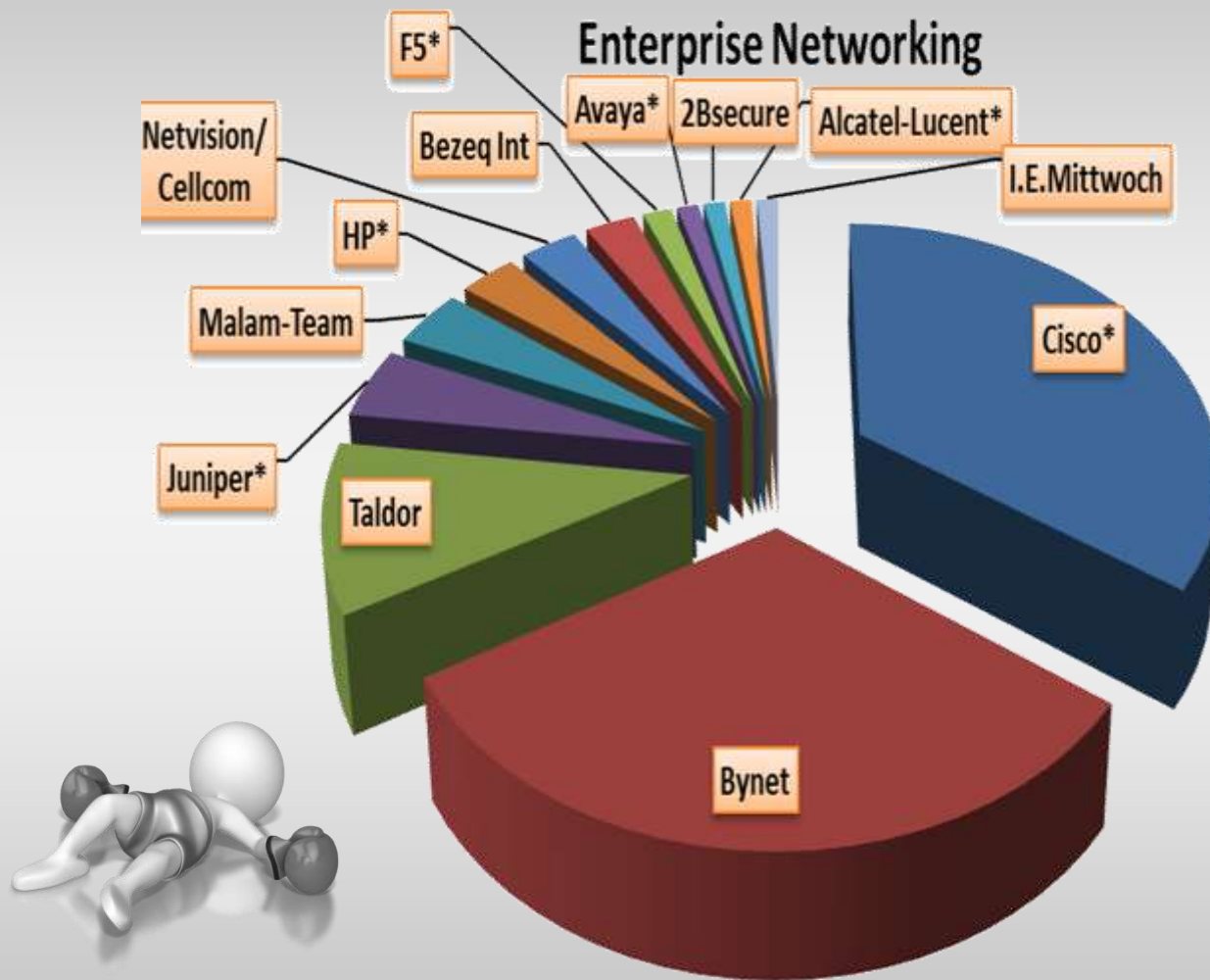

- One1
- EMET
- Radware*
- Partner/012
- Riverbed*
- Brocade*
- Matrix
- Minicom
- DELL*
- A10*

All amounts in M \$ USD

We rank VENDORS by
REVENUE
and
CLIENT MINDSHARE



Dr. Jimmy Schwarzkopf's work Copyright STKI@2012
Do not remove source or attribution from any slide, graph or portion of graph

Comparison Security Appliances 2012

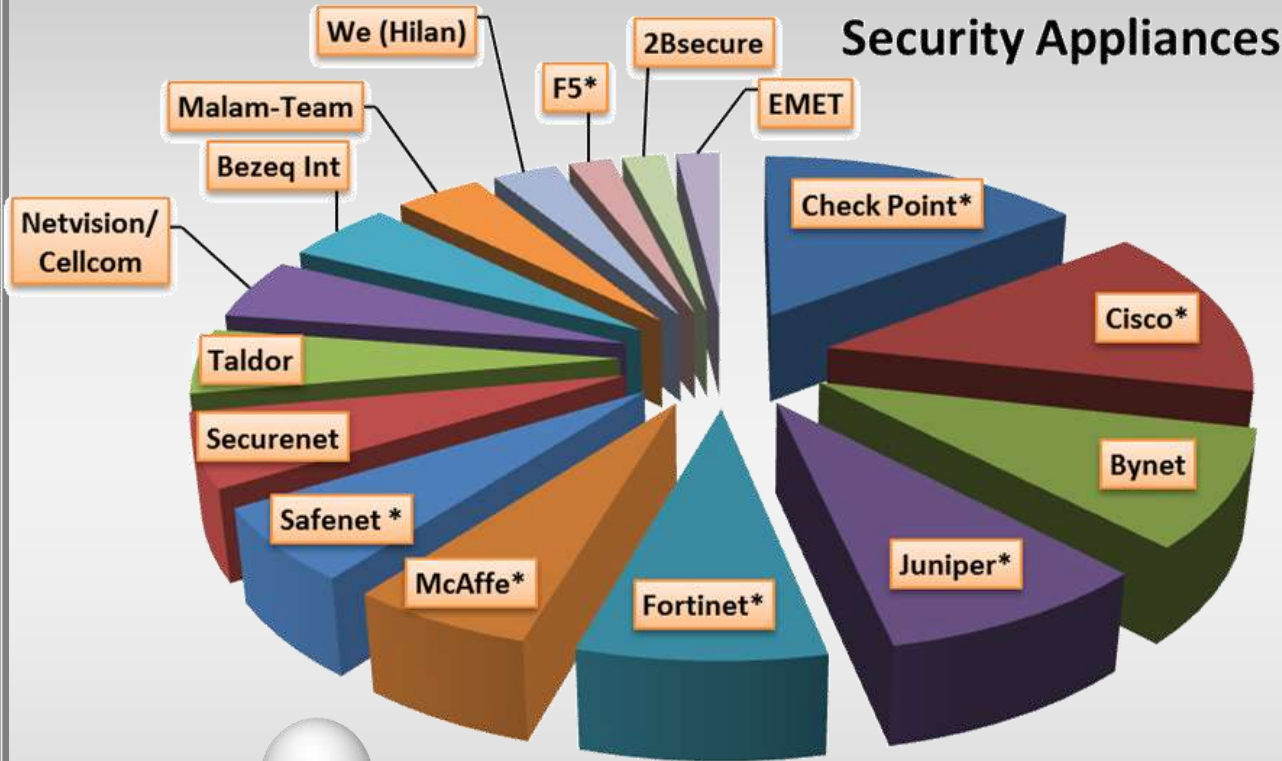

| |
|----------------|
| New Age |
| Websense* |
| Partner/012 |
| Aman Computers |
| Crossbeam* |
| Radware* |
| BlueCoat* |
| Virgonet |

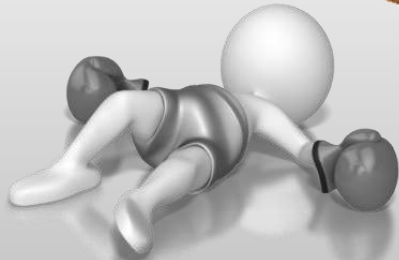

All amounts in M \$ USD

We rank VENDORS by
REVENUE
and
CLIENT MINDSHARE

Comparison Networking (other) 2012

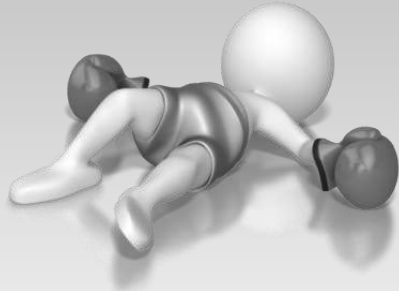

VoIP/Call Center

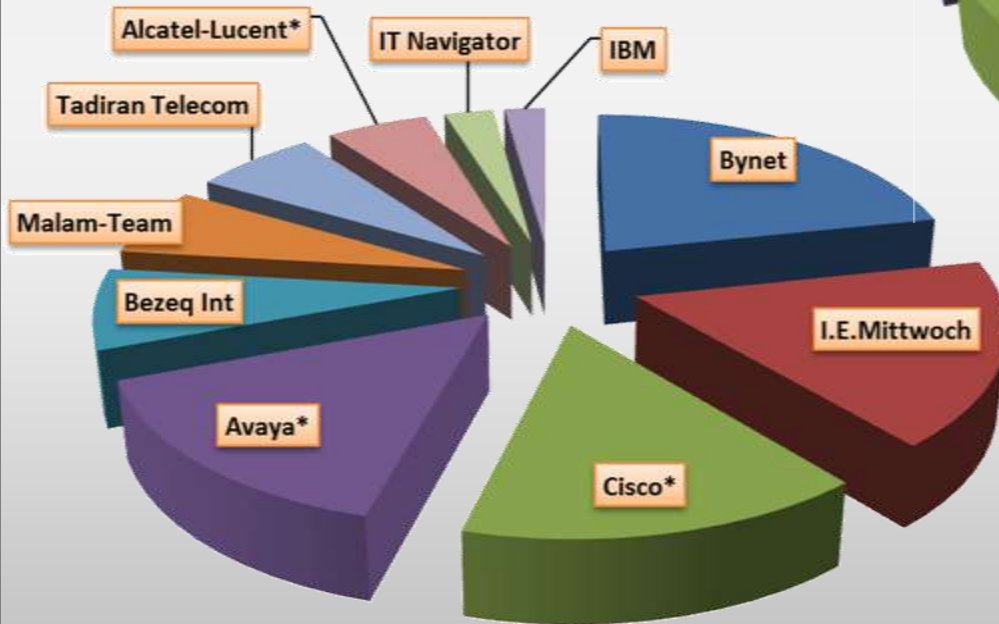

Videoconferencing Equipment

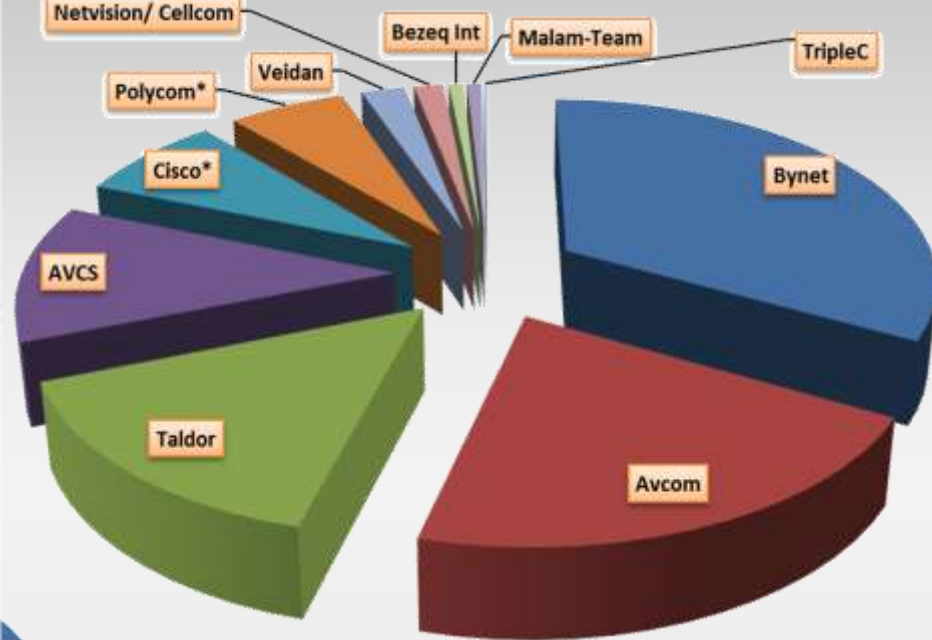

All amounts in M \$ USD



Dr. Jimmy Schwarzkopf's work Copyright STKI@2012
Do not remove source or attribution from any slide, graph or portion of graph

We rank VENDORS by
REVENUE
and
CLIENT MINDSHARE



Printer Market



| 2011 | | 2012 | | 2013 | | |
|-------|---------|-------|---------|-------|----------------------|---------|
| 124.0 | -11.29% | 110.0 | -13.64% | 95.0 | printers | Printer |
| 85.0 | 4.71% | 89.0 | 2.25% | 91.0 | toners/ink/refillers | |
| 209.0 | -4.78% | 199.0 | -6.53% | 186.0 | totals | |

We rank VENDORS by
REVENUE
 and
CLIENT MINDSHARE

All amounts in M \$ USD



Comparison Printers 2012

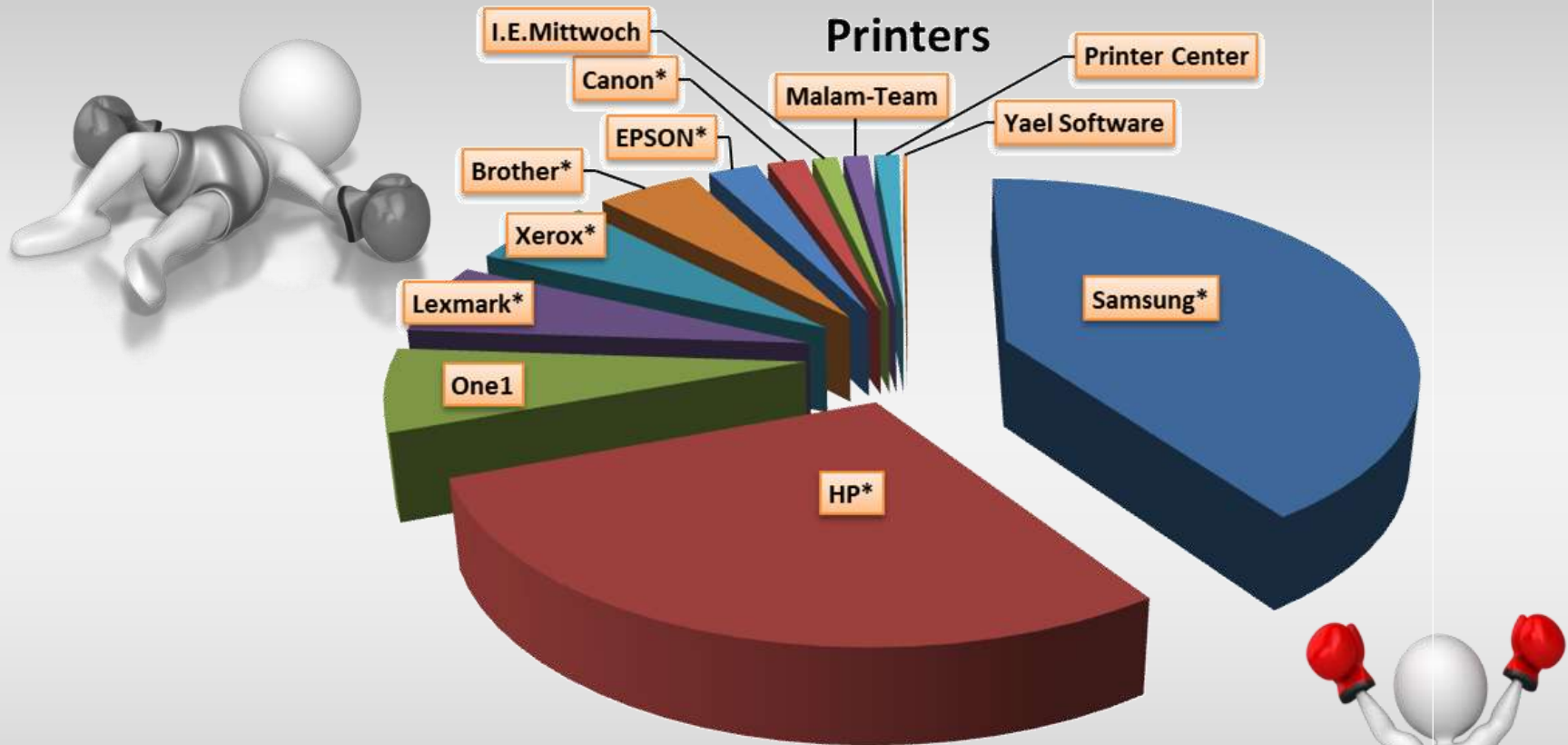

All amounts in M \$ USD

Dr. Jimmy Schwarzkopf's work Copyright STKI@2012
Do not remove source or attribution from any slide, graph or portion of graph

We rank VENDORS by
REVENUE
and
CLIENT MINDSHARE



Specialty Hardware Market



| 2011 | | 2012 | | 2013 | |
|--------------|--------------|--------------|--------------|--------------|---|
| 60.0 | 3.33% | 62.0 | 4.84% | 65.0 | Self Service Appliances (ATMs, Kiosks, etc) |
| 30.0 | 6.67% | 32.0 | 9.38% | 35.0 | Point of Sale Appliances |
| 70.0 | 5.71% | 74.0 | 9.46% | 81.0 | Data Center Physical Infrastructure |
| 90.0 | 4.44% | 94.0 | 4.26% | 98.0 | miscellaneous: Computer Supplies |
| 250.0 | 4.80% | 262.0 | 6.49% | 279.0 | totals |

We rank VENDORS by
REVENUE
 and
CLIENT MINDSHARE

All amounts in M \$ USD



We rank VENDORS by
REVENUE
 and
CLIENT MINDSHARE

Data Center Physical Equipment

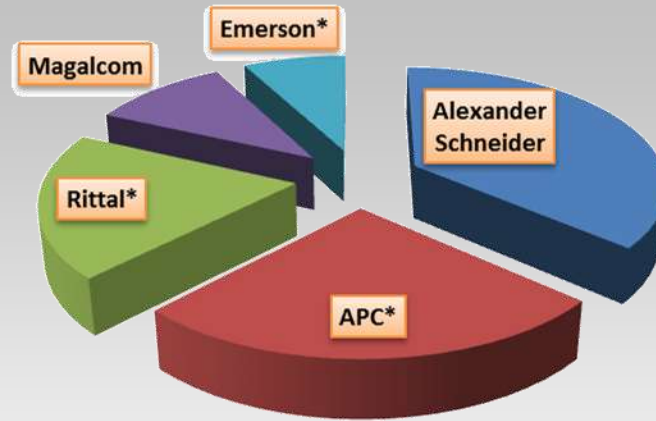

POS Appliances

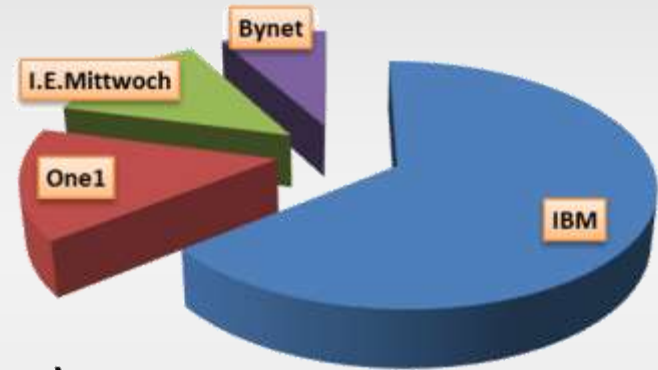

Self-Service (ATM, Kiosks, etc)

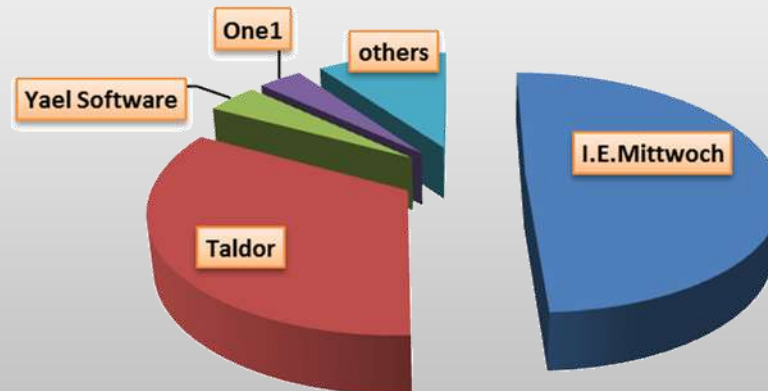

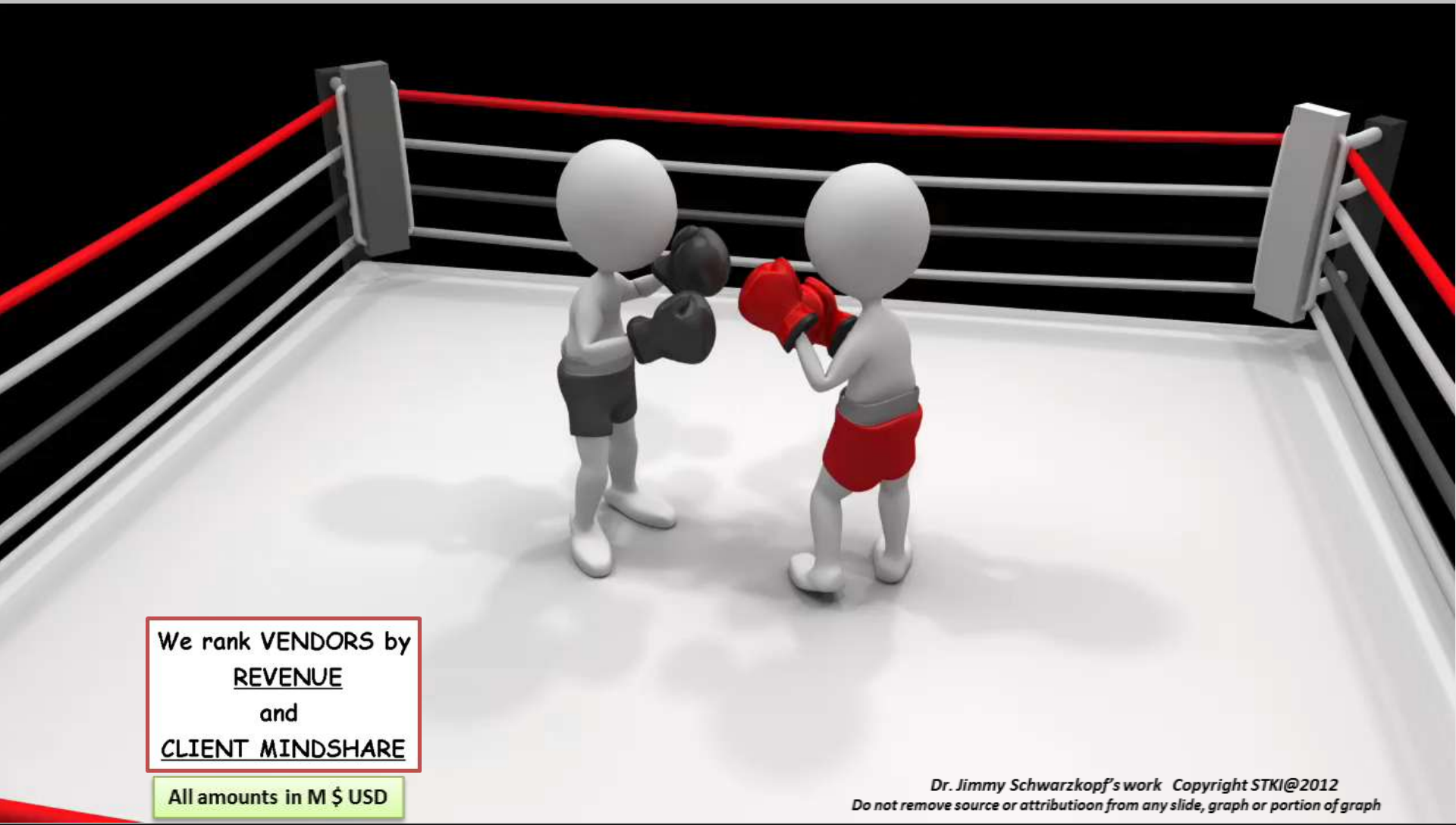

We rank VENDORS by
REVENUE
and
CLIENT MINDSHARE

All amounts in M \$ USD

*Dr. Jimmy Schwarzkopf's work Copyright STKI@2012
Do not remove source or attribution from any slide, graph or portion of graph*

Israel: IT Software Total Market 2011-2013

| 2011 | | 2012 | | 2013 |
|---------|-------|---------|-------|---------|
| 1,221.2 | 5.49% | 1,288.2 | 7.90% | 1,390.0 |

We rank VENDORS by
REVENUE
and
CLIENT MINDSHARE

All amounts in M \$ USD



Top Software Vendors

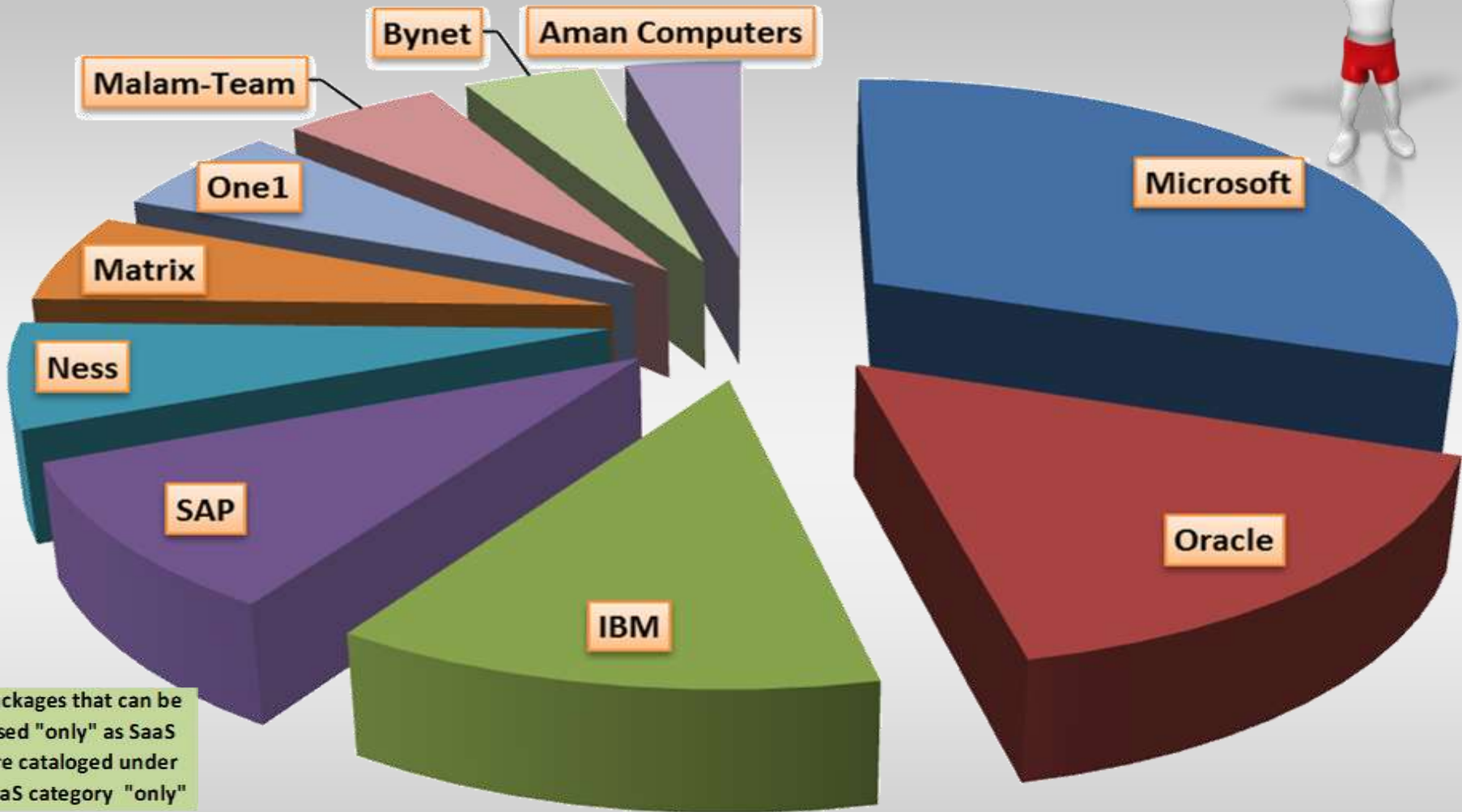

Packages that can be used "only" as SaaS are cataloged under SaaS category "only"

We rank VENDORS by
REVENUE
and
CLIENT MINDSHARE

All amounts in M \$ USD



Software Categories 1

| | | | |
|------------------------------|---|---|--|
| System Infrastructure | operating systems | מערכות הפעלה | מערכות תשתיות |
| | data bases | בסיסי נתונים | |
| | middleware | כלי תווכה | |
| | other | אחר | |
| IT Mgmt Tools | Service Desk | Service Desk | מערכות ניהול |
| | System Control & Mgmt Systems (BSM, APM, BTM) | שליטה ובקרה (כל הסוגים כולל חויית משתמש, ניטור טרנזאקציות וכד') | |
| | storage & backup | אחסון וגיבוי | |
| | Security | אבטחת מידע | |
| | other | אחר | |
| Office of the CIO | Project & Portfolio Management | ניהול פרויקטים ופורטפוליו | מערכות לניהול IO (תחום Office of the CIO) |
| | Asset Management | ניהול נכסי IT | |
| | Governance Risk & Compliance | ציות רגולציות וניהול סיכונים | |
| | other | אחר | |
| Development Tools | Development and ALM (including testing) | פיתוח ובדיקות תוכנה | כלי פיתוח |
| | mobile development tools | פלטפורמות לפיתוח מובייל | |
| | PLM | PLM | |
| | LMS learning management | כלי ניהול למידה - LMS | |
| | other | אחר | |

We rank VENDORS by
REVENUE
and
CLIENT MINDSHARE

All amounts in M \$ USD



System Infrastructure Software Market



| 2011 | | 2012 | | 2013 | | |
|--------------|--------------|--------------|---------------|--------------|-------------------|---------------|
| 78.0 | -3.85% | 75.0 | -6.67% | 70.0 | operating systems | Basic Systems |
| 83.0 | -3.61% | 80.0 | -2.50% | 78.0 | data bases | |
| 65.0 | 10.77% | 72.0 | 4.17% | 75.0 | middleware | |
| 226.0 | 0.44% | 227.0 | -1.76% | 223.0 | totals | |

We rank VENDORS by
REVENUE
 and
CLIENT MINDSHARE

All amounts in M \$ USD



Comparison

System Infrastructure 2012

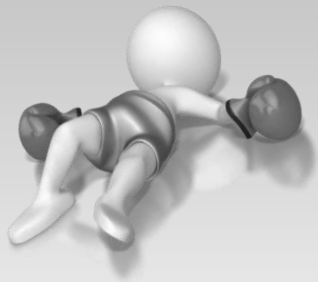

Operating Systems

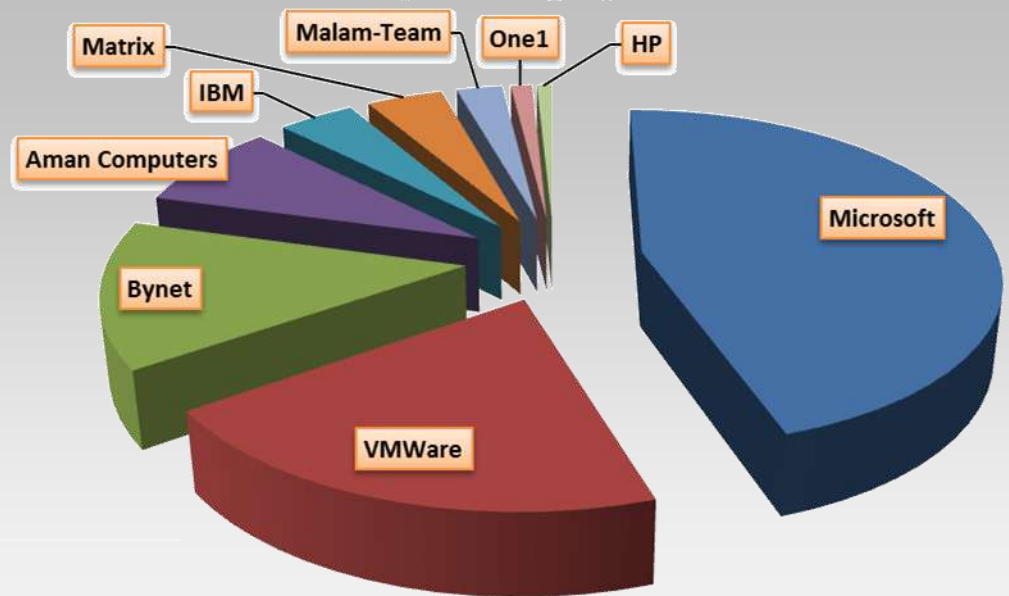

Middleware

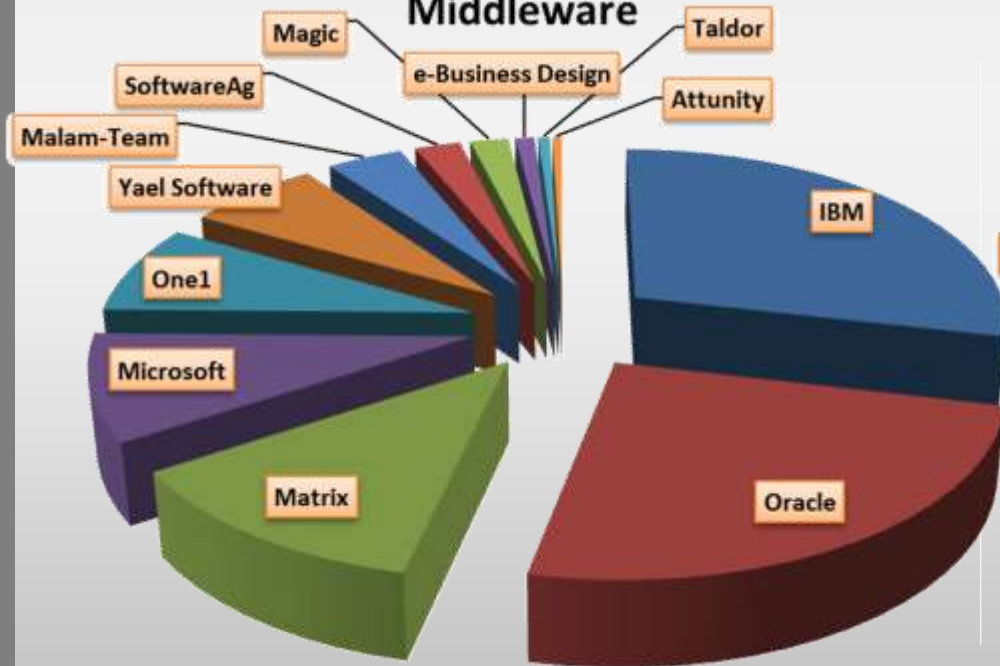

DBMS

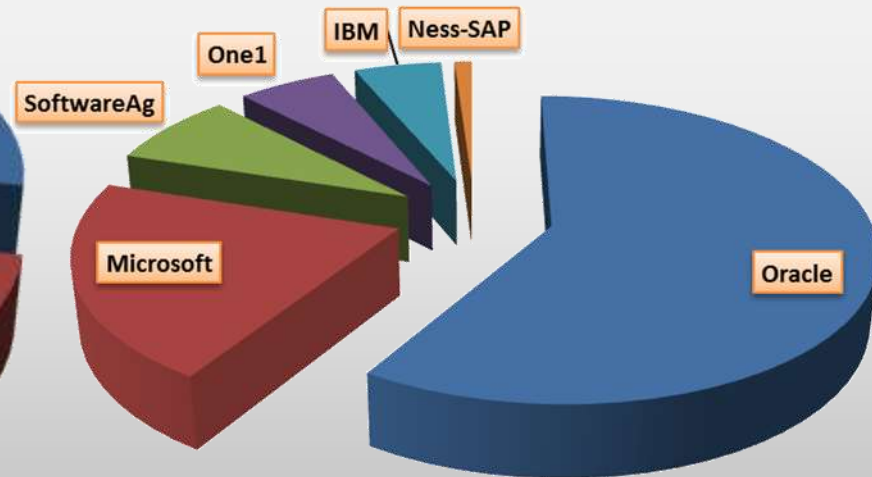

All amounts in M \$ USD

We rank VENDORS by
REVENUE
and
CLIENT MINDSHARE

IT Management Tools Software Market

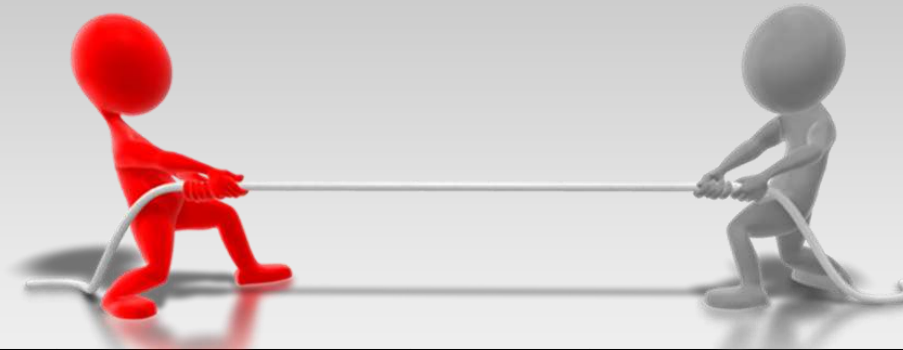

| 2011 | | 2012 | | 2013 | |
|--------------|--------------|--------------|--------------|--------------|--------------------------|
| 15.0 | 13.33% | 17.0 | 17.65% | 20.0 | Service Desk |
| 75.0 | 4.00% | 78.0 | 6.41% | 83.0 | Systems Control and Mgmt |
| 64.0 | 6.25% | 68.0 | 5.88% | 72.0 | Storage/ backup |
| 127.0 | 3.94% | 132.0 | 6.06% | 140.0 | Security |
| 281.0 | 4.98% | 295.0 | 6.78% | 315.0 | totals |

We rank VENDORS by
REVENUE
 and
CLIENT MINDSHARE

All amounts in M \$ USD



Comparison IT Management Tools 1 Market 2012

Service Desk

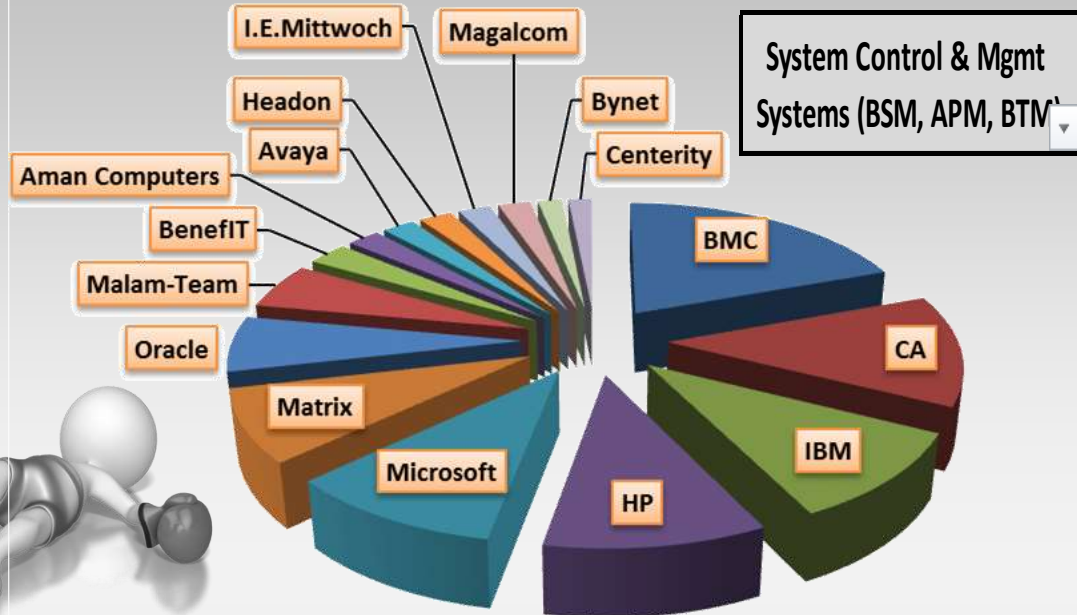
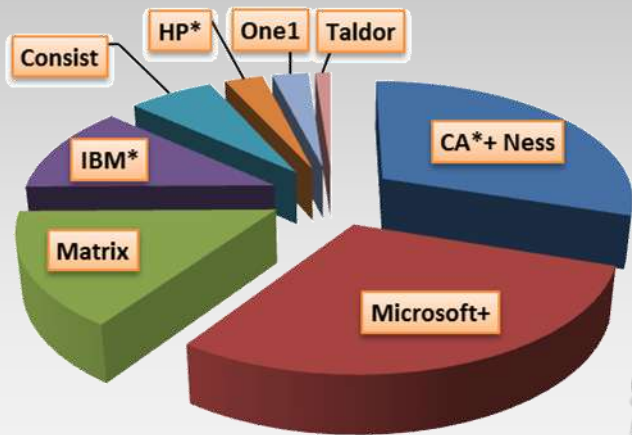

Storage & Backup

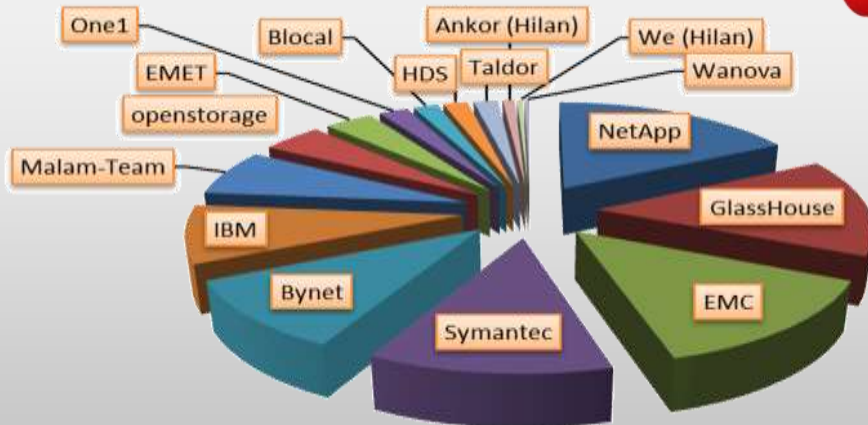

| |
|---------------------|
| Alexander Schneider |
| Trigerplus |
| ACS |
| Agile Sparks |
| GlassHouse |
| Ness |
| Ankor (Hilan) |
| IT Analyzer |
| One1 |
| Taldor |
| We (Hilan) |
| evolen |
| IntegrITy |
| neebula |
| venotion |

System Control & Mgmt Systems (BSM, APM, BTM)

Comparison

IT Management Tools 2 Market 2012

We rank VENDORS by
REVENUE
and
CLIENT MINDSHARE

Security Software

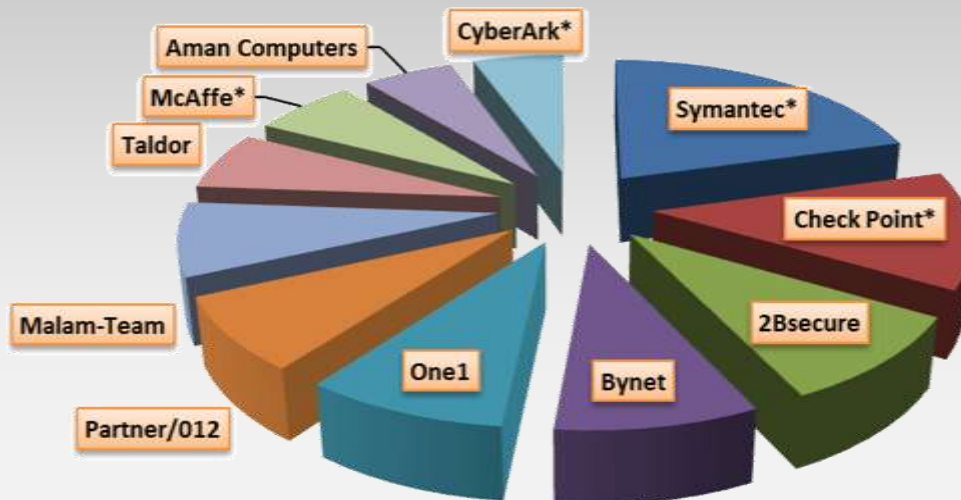

| |
|--------------------|
| CyberArk* |
| calcom |
| Innocom |
| Netvision/ Cellcom |
| Trustnet |
| We (Hilan) |
| IBM* |
| Accesslayers* |
| EMET |
| I.E.Mittwoch |
| Imperva |
| Microsoft |

| |
|--------------|
| New Age |
| Securenet |
| We b e n s e |
| Oracle |
| ARX |
| Av net |
| ForeScout |
| Fortinet |
| Promisec |
| We b e n s e |
| Comda |
| MultiPoint |

| |
|----------------|
| Oranus |
| Wise |
| Brillix |
| Covertix |
| GreenSQL |
| IntegrITy |
| Intellinx |
| Kaspersky Labs |
| Mobisec |
| Prolink |

| |
|----------------|
| Radvision |
| Secure Islands |
| Varonis |
| Waterfall |
| ACS |
| Barracuda |
| Networks |
| Virgonet |
| SoftwareAg |
| Cryptzone |

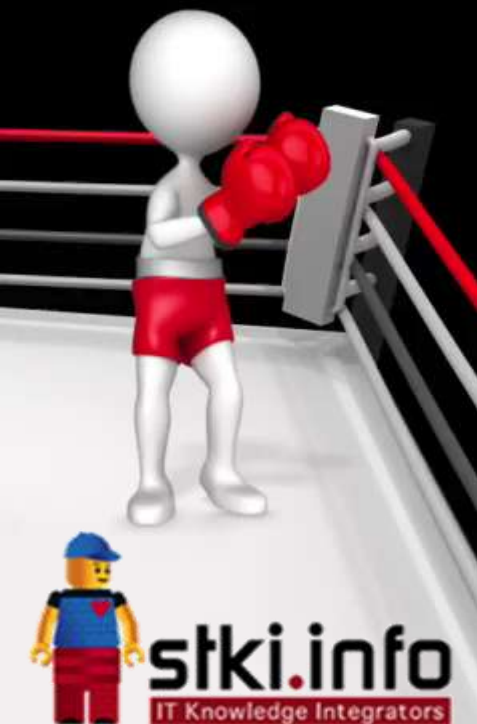

Office of the CIO Software Market



| 2011 | | 2012 | | 2013 | |
|------|--------|------|--------|------|-------------------------------|
| 7.0 | 28.57% | 9.0 | 22.22% | 11.0 | Portfolio Mgmt |
| 15.0 | 13.33% | 17.0 | 29.41% | 22.0 | Project Management |
| 9.0 | 22.22% | 11.0 | 36.36% | 15.0 | Asset Mgmt |
| 50.0 | 8.00% | 54.0 | 14.81% | 62.0 | Governance, Risk & Compliance |

We rank VENDORS by
REVENUE
 and
CLIENT MINDSHARE

All amounts in M \$ USD



Comparison Office of CIO Software Market 2012

Project & Portfolio Management Tools

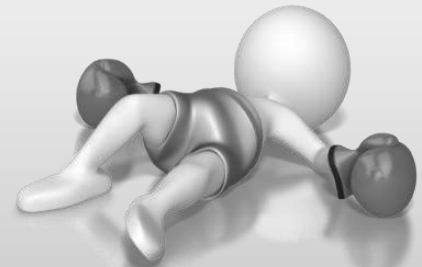
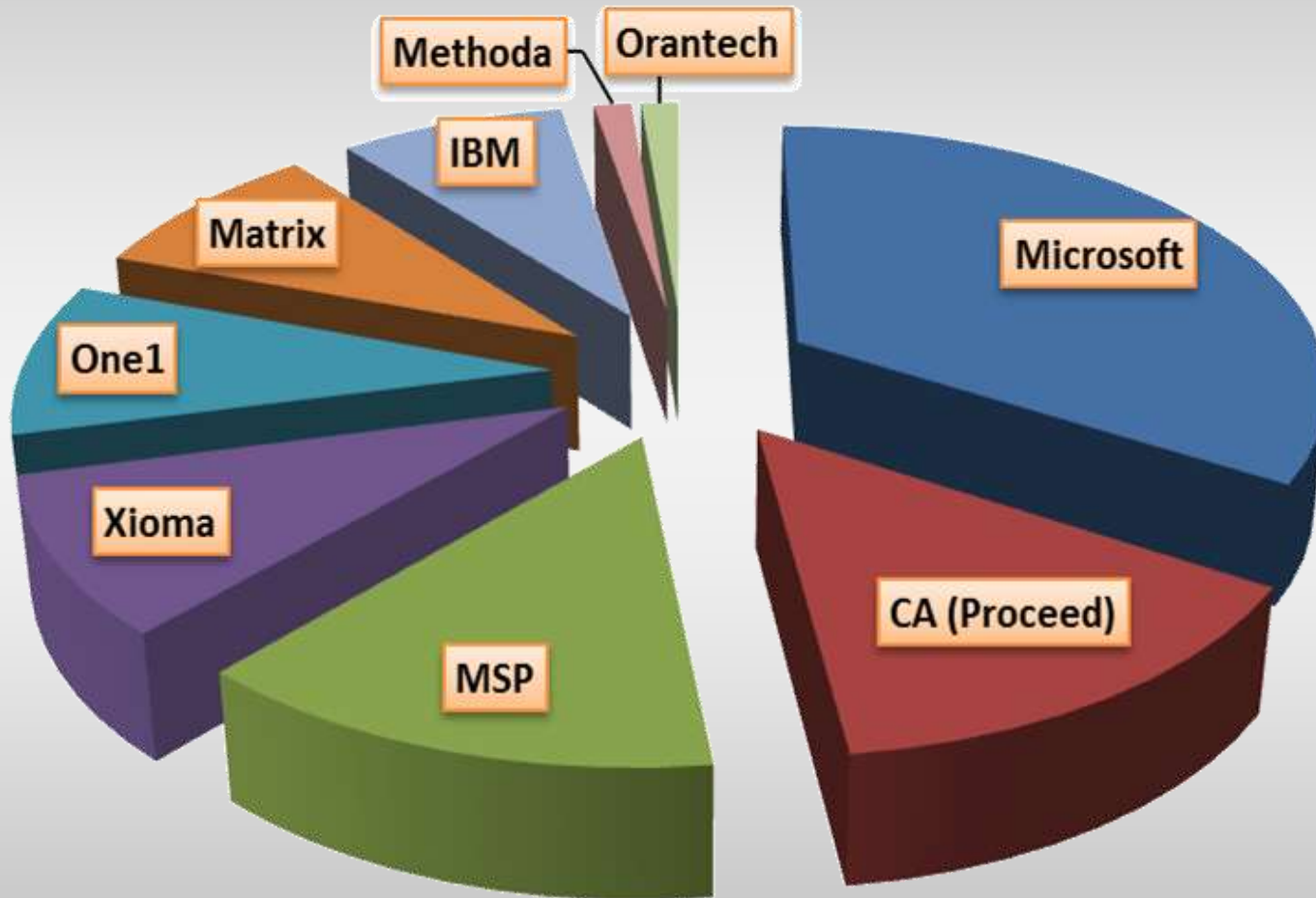

Software Development Tool Market



| 2011 | | 2012 | | 2013 | |
|--------------|--------------|--------------|---------------|--------------|---------------------------|
| 70.0 | 2.86% | 72.0 | 11.11% | 80.0 | development & ALM tools |
| 9.0 | 22.22% | 11.0 | 36.36% | 15.0 | PLM tools |
| 23.0 | -8.70% | 21.0 | -4.76% | 20.0 | testing tools |
| 12.0 | 25.00% | 15.0 | 26.67% | 19.0 | mobile dev tools |
| 5.0 | 20.00% | 6.0 | 50.00% | 9.0 | LMS learning/hatmaa tools |
| 119.0 | 5.04% | 125.0 | 14.40% | 143.0 | totals |

We rank VENDORS by
REVENUE
 and
CLIENT MINDSHARE

All amounts in M \$ USD

Comparison Development Tool Software Market 2012

Development & ALM (includes testing tools)

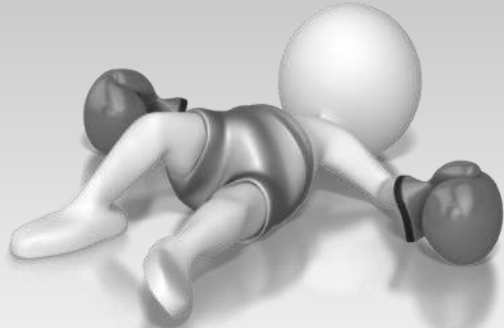

Mobile Development Tools

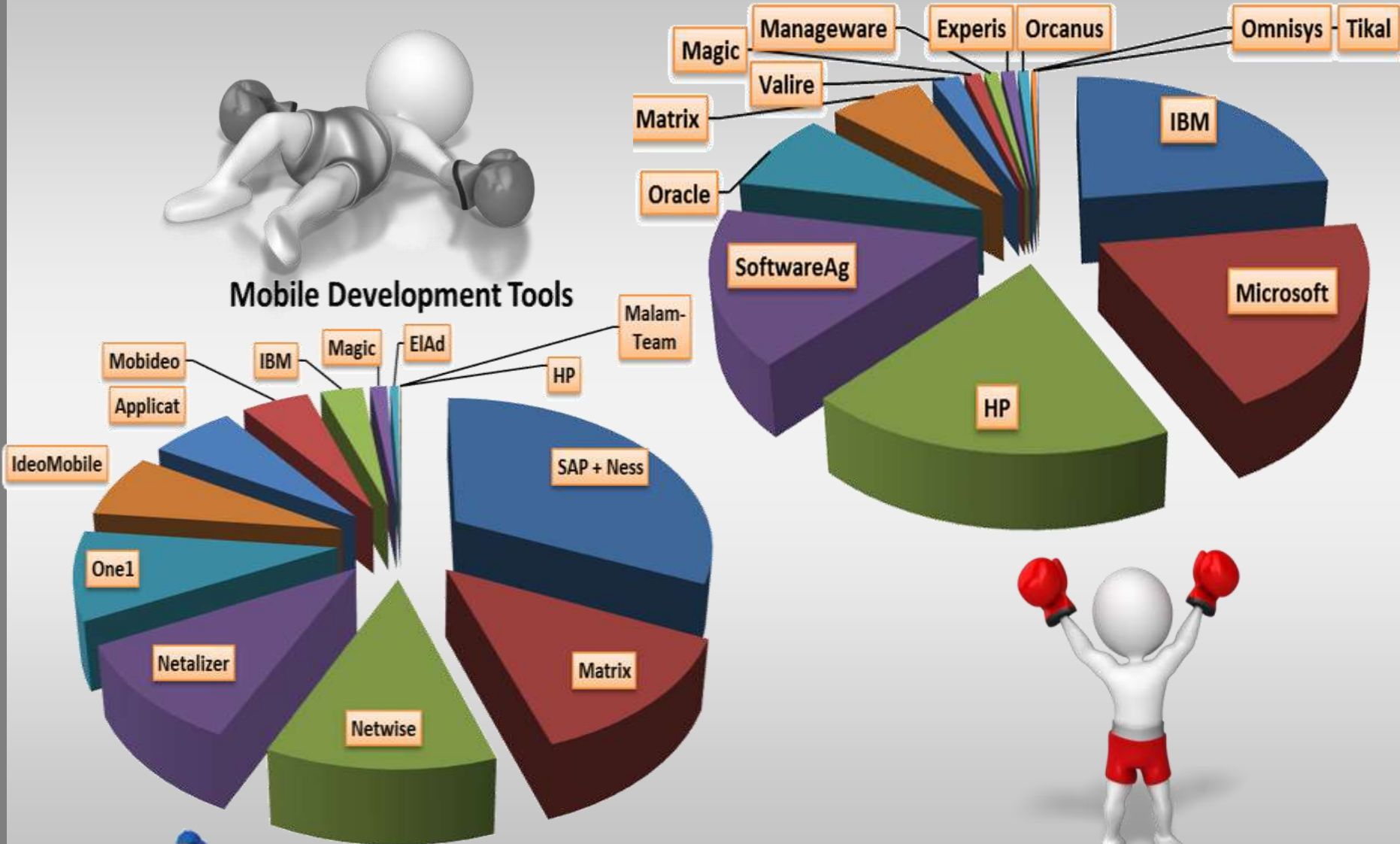

We rank VENDORS by
REVENUE
and
CLIENT MINDSHARE

LMS Learning Management

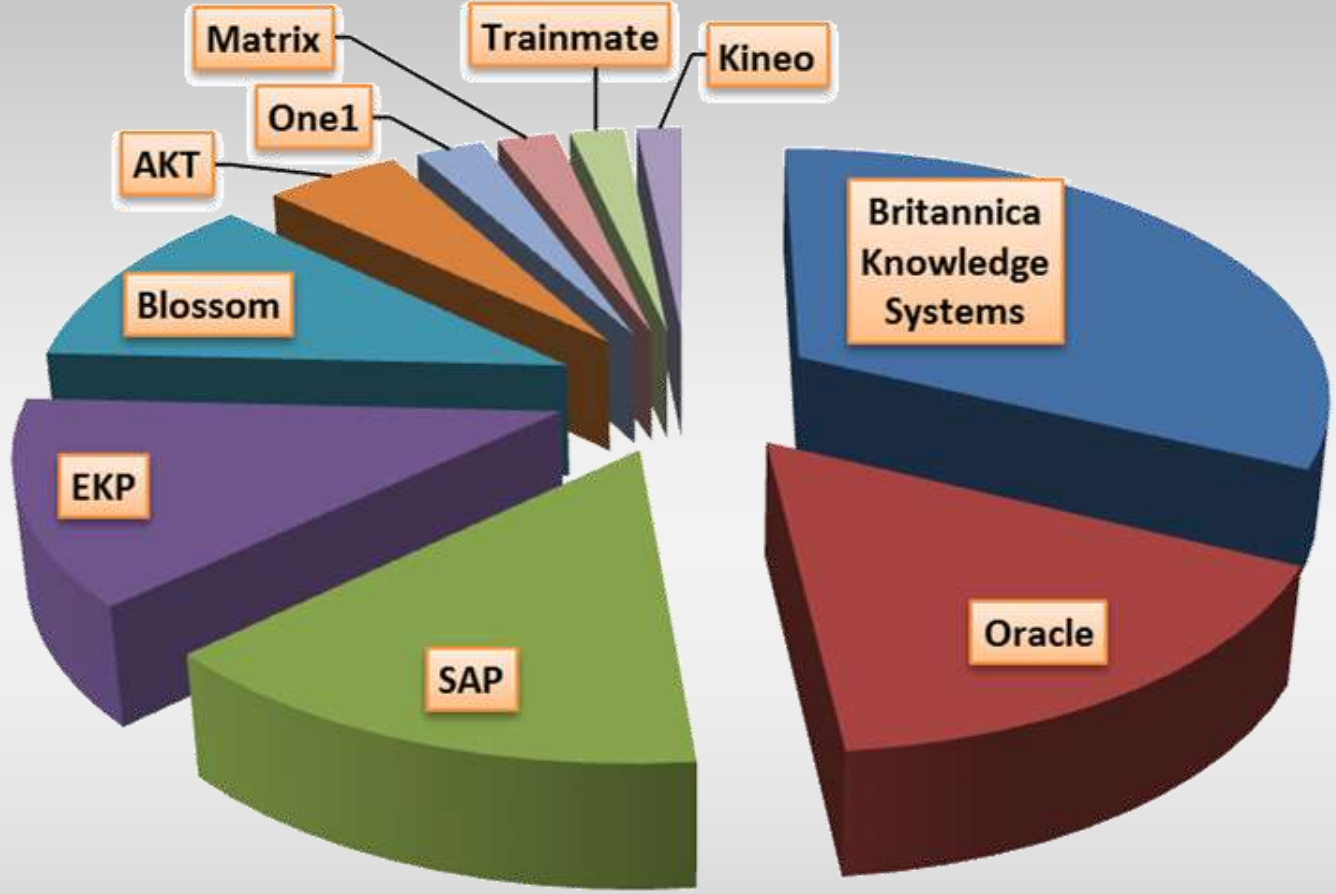

Software Categories 2

| | | | |
|------------------------|--|---|-------------------------|
| Information Management | Office Productivity (Microsoft Office, etc.) | תוכנות משרדיות (יומן, דוא"ל - MS Office) | כלי ניהול מידע תשתיתיים |
| | Enterprise portals, collaboration & social tools | פורטלים ארגוניים, כל שיתופיות ורשתות חברתיות ארגוניות | |
| | Analytics/ BI/DM/ EPM tools | כלי אחזור BI, כריית נתונים, כל EPM ניהול ביצועי ארגון | |
| | information mgmt (MDM, ETL, EII etc) | ניהול נתונים (MDM, ETL, EII) | |
| | Document mgmt and search tools | ניהול מסמכים, מנועי חיפוש | |
| | Output mgmt tools | כלי ניהול פלטים/הדפסות | |
| | multimedia mgmt tools (video, etc) | ניהול תכני מולטימדיה | |
| | other | אחר | |
| Business Applications | ERP | ERP | אפליקציות עסקיות |
| | CRM | CRM | |
| | BPM | BPM | |
| | WEB - social mng. | ניהול אתרים + מדיה חברתית | |
| | GIS & location based | אפליקציות מבוססות מקום GIS | |
| | Vertical (core business) | ניהול לבת הארגון/ורטיקלים | |
| | other | אחר | |

We rank VENDORS by
REVENUE
and
CLIENT MINDSHARE

All amounts in M \$ USD

Information Management Software Market

| 2011 | | 2012 | | 2013 | |
|--------------|--------------|--------------|--------------|--------------|--|
| 32.0 | 3.13% | 33.0 | 6.06% | 35.0 | office productivity |
| 62.0 | 4.84% | 65.0 | 10.77% | 72.0 | portals, collaboration & social |
| 47.0 | 6.38% | 50.0 | 6.00% | 53.0 | document mgmt & search tools |
| 10.0 | 20.00% | 12.0 | 16.67% | 14.0 | multimedia mgmt tools (video and others) |
| 12.0 | 16.67% | 14.0 | 14.29% | 16.0 | output mgmt tools |
| 100.0 | 12.00% | 112.0 | 10.71% | 124.0 | Analytics/BI / MDM/ ETL tools |
| 263.0 | 8.75% | 286.0 | 9.79% | 314.0 | totals |

We rank VENDORS by
REVENUE
 and
 CLIENT MINDSHARE

All amounts in M \$ USD



Comparison Information Management Software Market

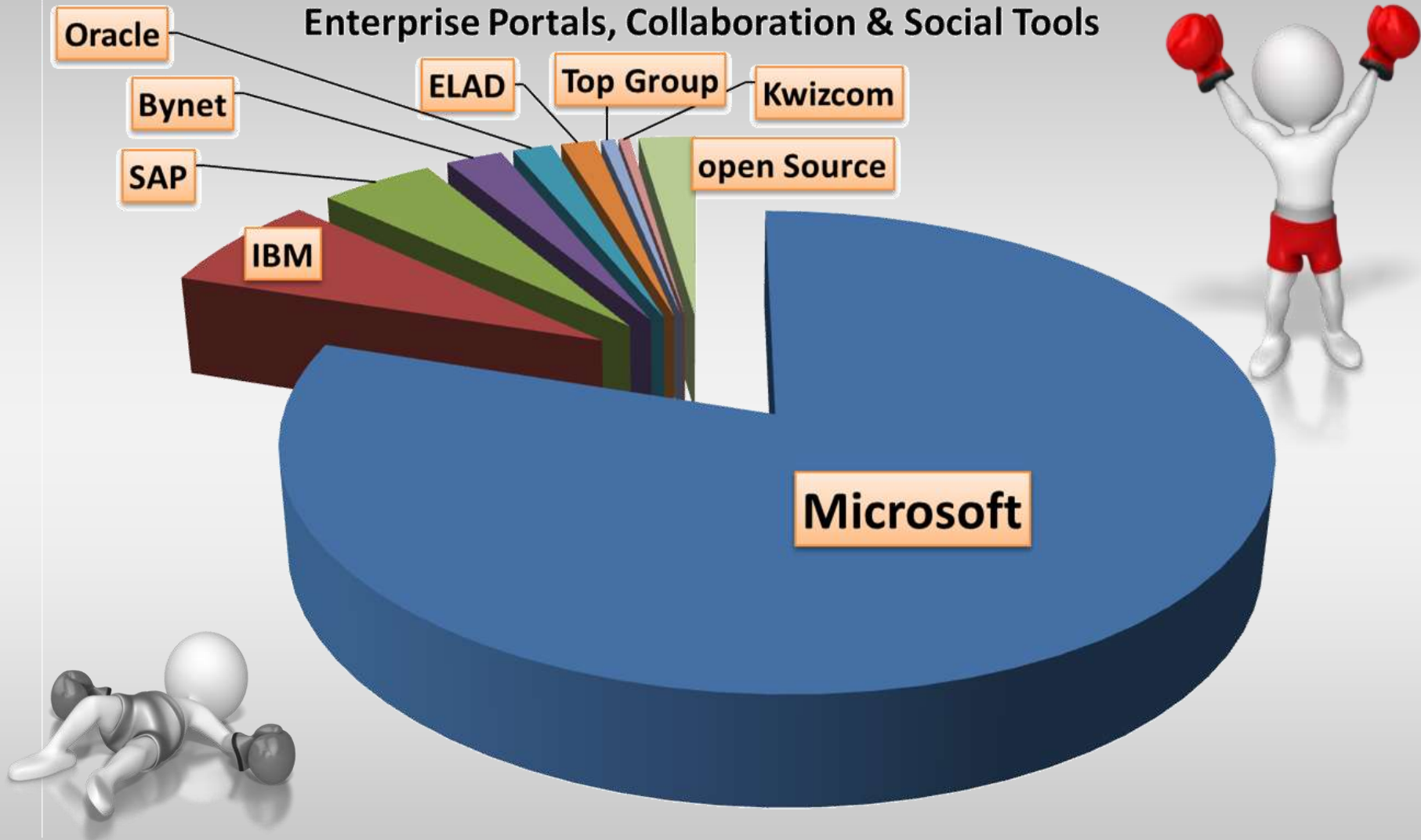

Comparison Information Management Software Market 2

Analytics/Bi/DW/EPM Tools

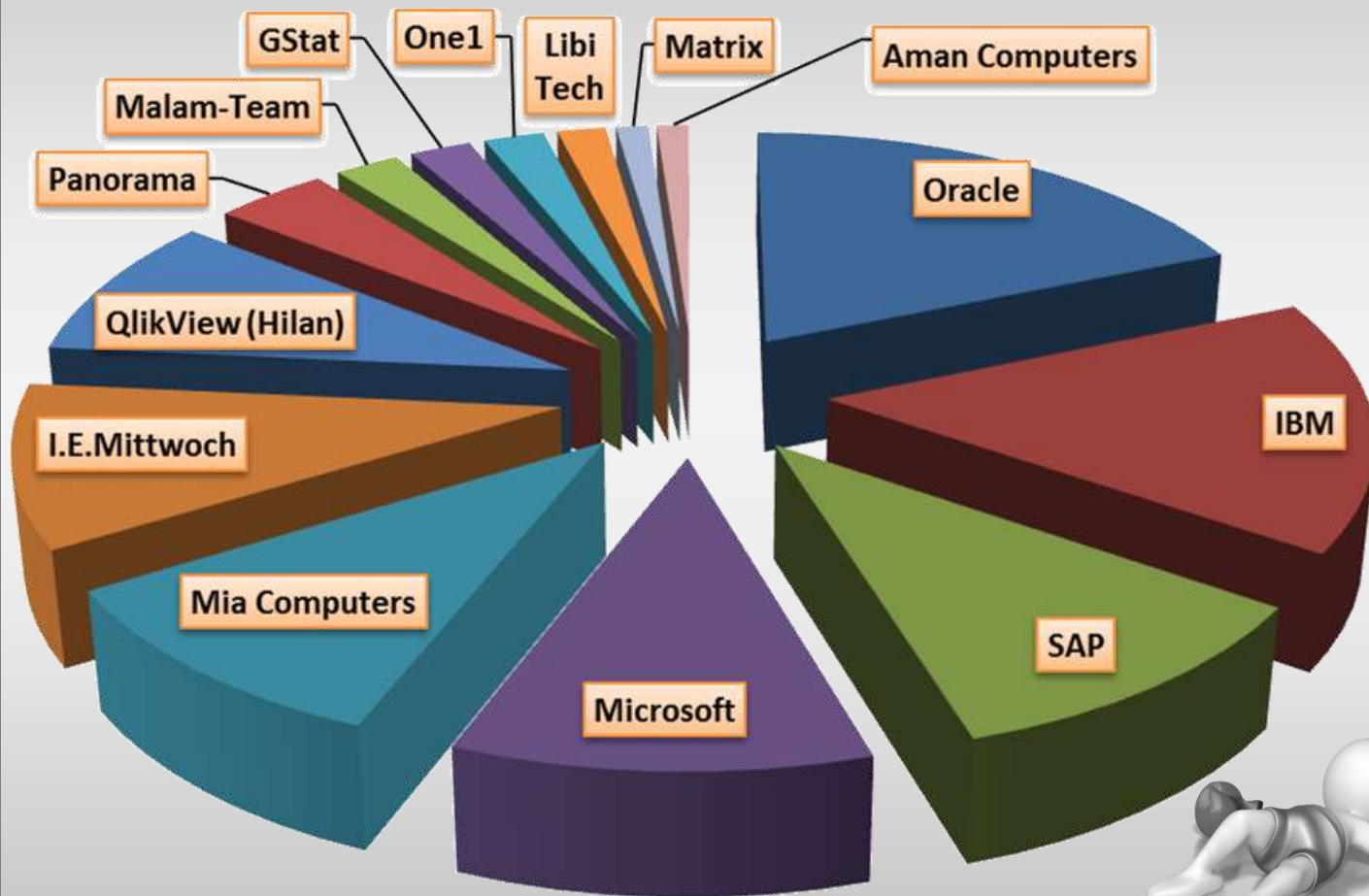

| |
|---------------|
| Ness |
| Yael Software |
| SIT |
| Pilat |
| Point of View |
| Taldor |
| BDO |
| Eternity |

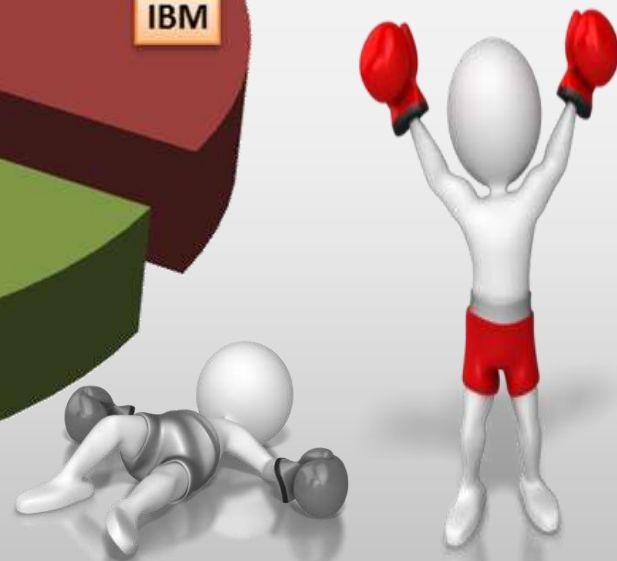

Comparison Information Management Software Market 3

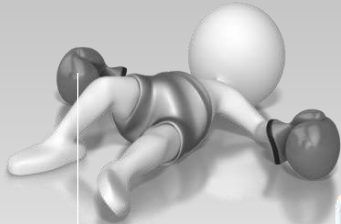

Document Mgmt. & Search Tools

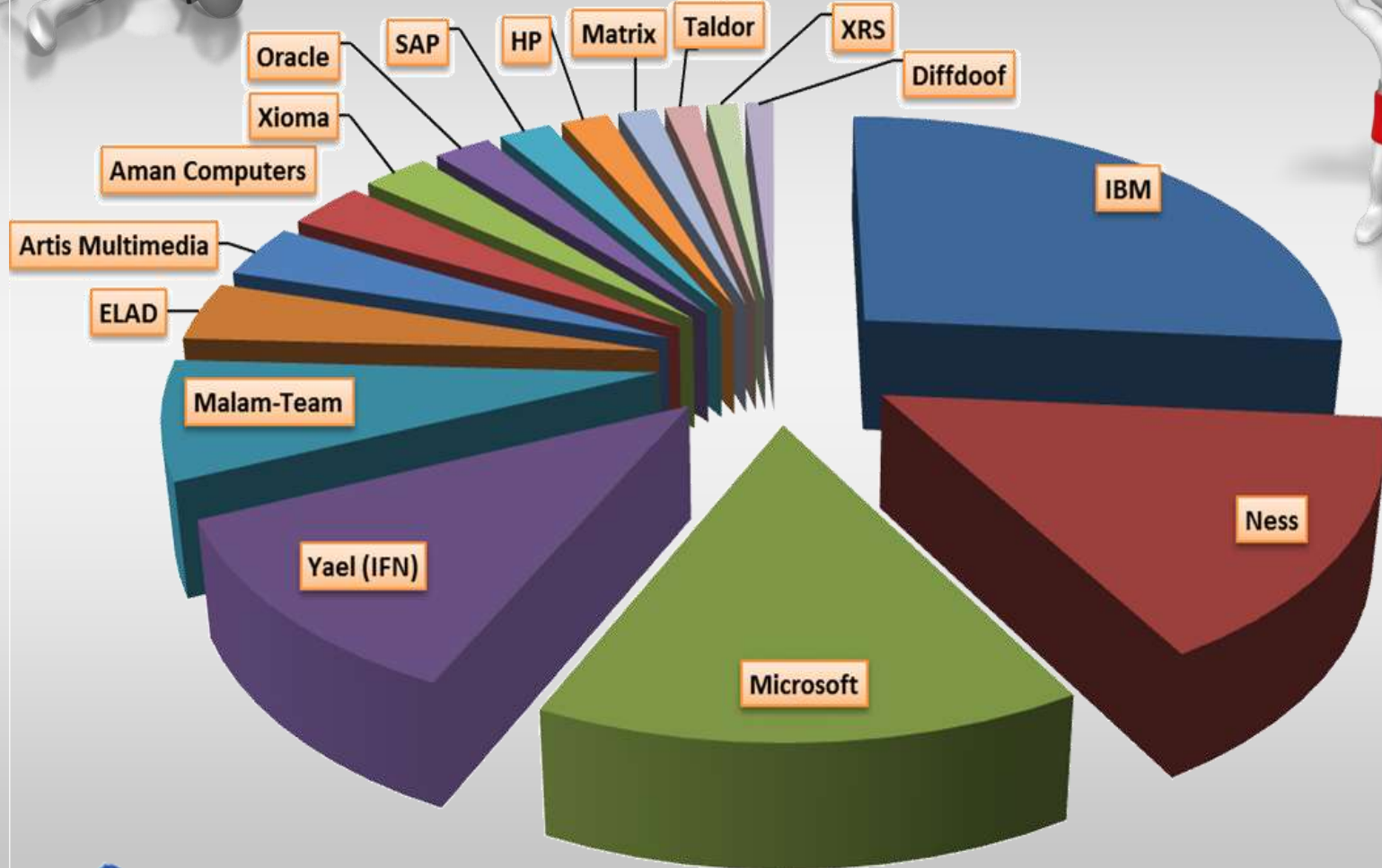

Business Application Software Market

| 2011 | | 2012 | | 2013 | |
|--------------|--------------|--------------|--------------|--------------|-------------------|
| 54.0 | 3.70% | 56.0 | 7.14% | 60.0 | core applications |
| 110.0 | 3.64% | 114.0 | 5.26% | 120.0 | ERP |
| 55.0 | 5.45% | 58.0 | 6.90% | 62.0 | CRM |
| 15.0 | 13.33% | 17.0 | 11.76% | 19.0 | BPM |
| 8.0 | 15.00% | 9.2 | 30.43% | 12.0 | WEB - Social mgmt |
| 9.2 | 8.70% | 10.0 | 20.00% | 12.0 | others |
| 251.2 | 5.18% | 264.2 | 7.87% | 285.0 | totals |

We rank VENDORS by
REVENUE
 and
CLIENT MINDSHARE

All amounts in M \$ USD



We rank VENDORS by
REVENUE
and
CLIENT MINDSHARE

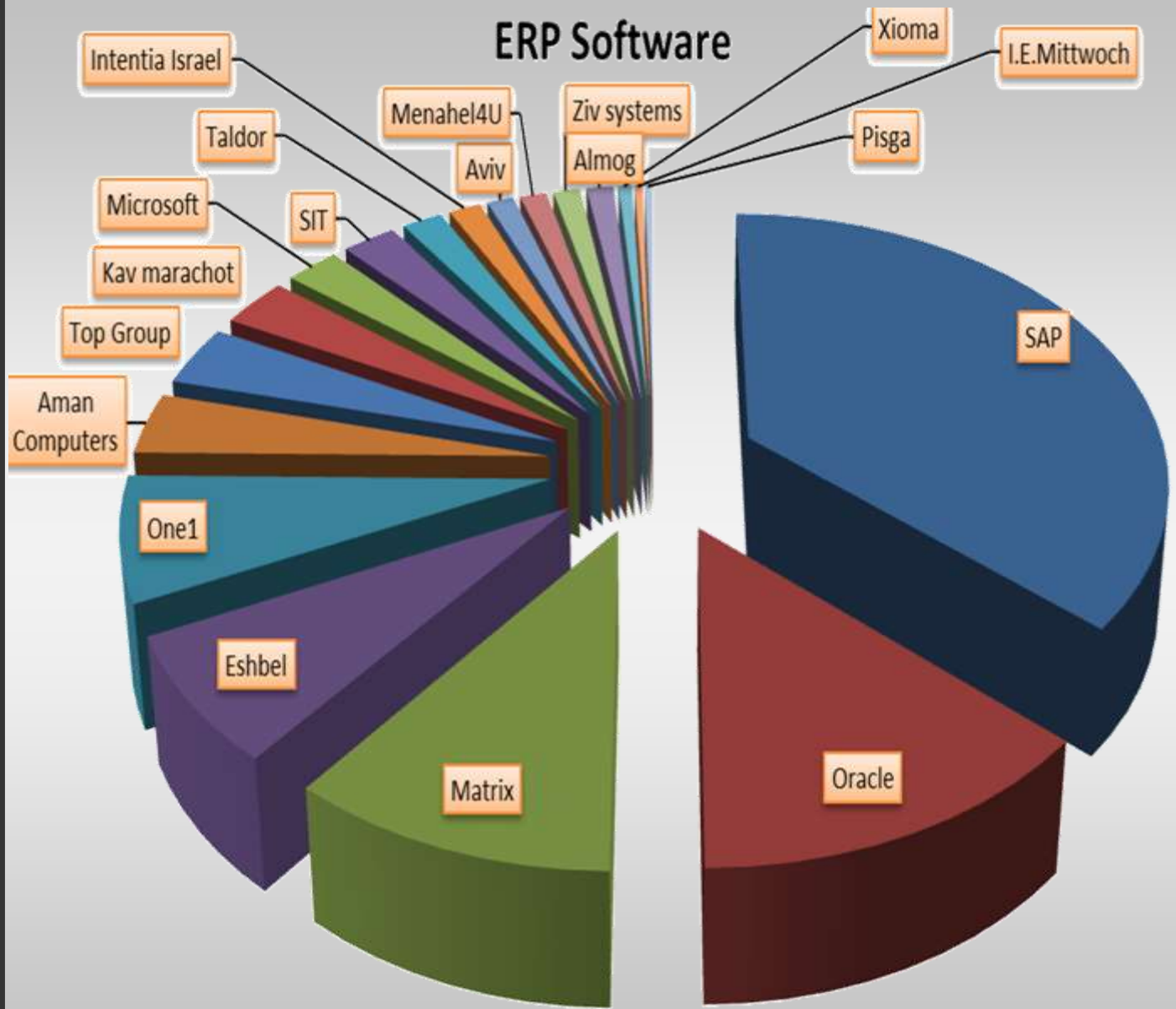

Dr. Jimmy Schwarzkopf's work Copyright STKI@2012
Do not remove source or attribution from any slide, graph or portion of graph

Packages that can be used "only" as SaaS are cataloged under SaaS category "only"

Comparison Business Application Software Market 2

Web & Social

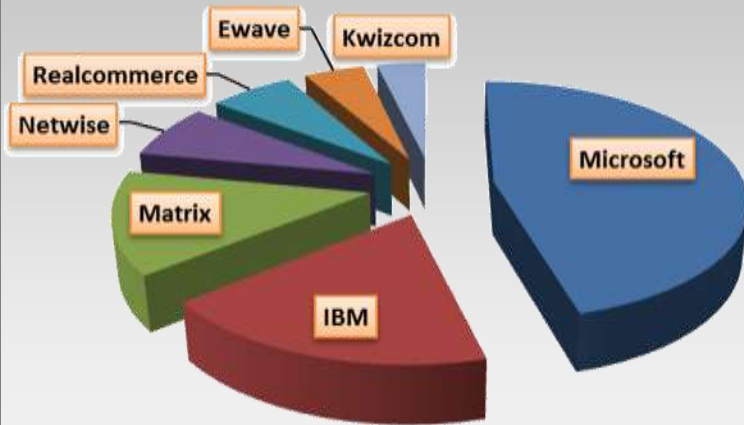

BPM

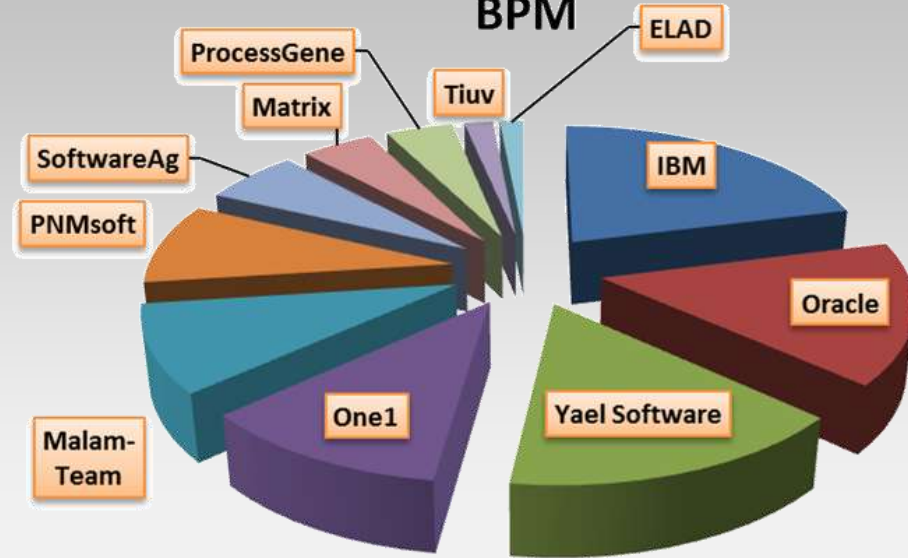

Packages that can be used "only" as SaaS are cataloged under SaaS category "only"

CRM Software Packages

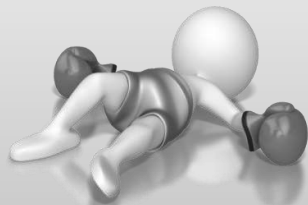
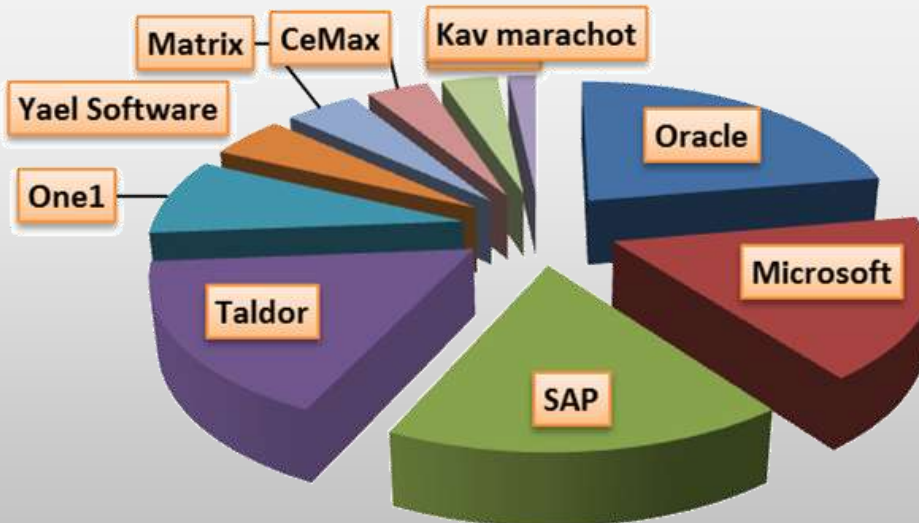

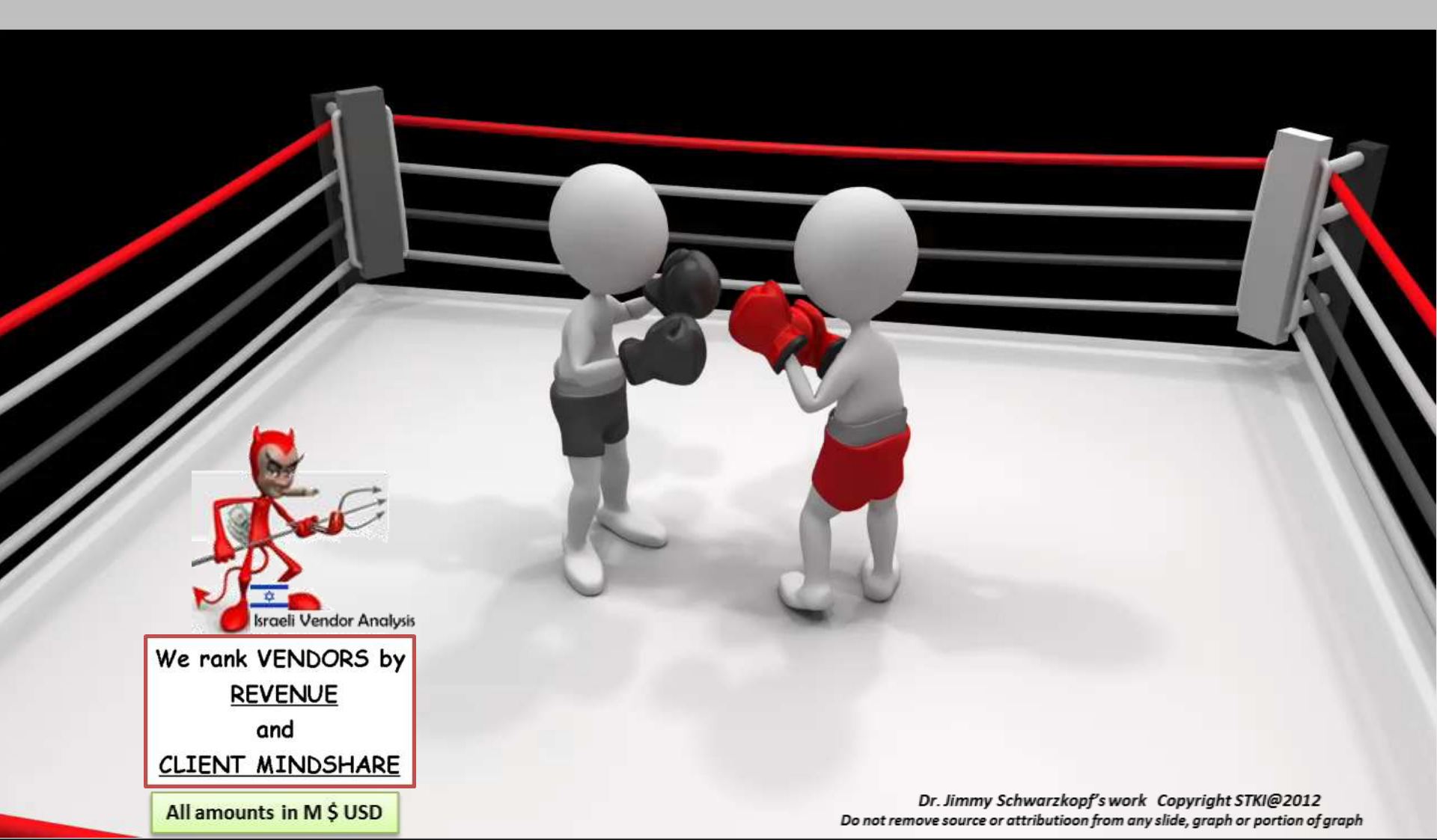

Israeli Vendor Analysis

We rank VENDORS by
REVENUE
and
CLIENT MINDSHARE

All amounts in M \$ USD

*Dr. Jimmy Schwarzkopf's work Copyright STKI@2012
Do not remove source or attribution from any slide, graph or portion of graph*

Israel: Value Added Services Market 2011-2013

| 2011 | | 2012 | | 2013 |
|---------|-------|---------|--------|---------|
| 2,997.0 | 4.07% | 3,119.0 | 11.61% | 3,481.0 |

We rank VENDORS by
REVENUE
and
CLIENT MINDSHARE

All amounts in M \$ USD



Top Value Added Services Vendors

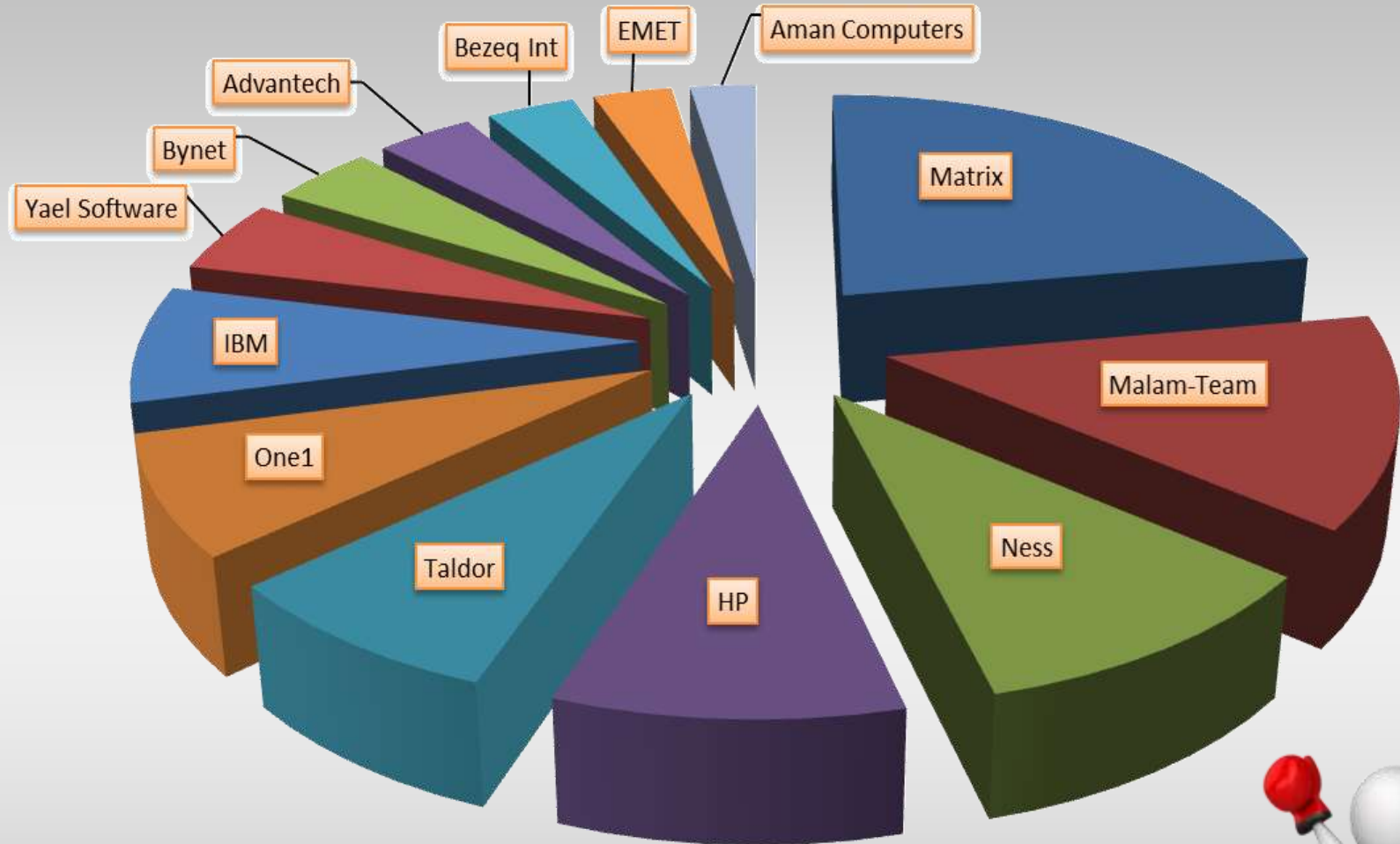

We rank VENDORS by
REVENUE
and
CLIENT MINDSHARE

All amounts in M \$ USD



Value Added Services Categories 1

| | | | |
|--------------------------|--|--|--|
| IT Consulting & Analysis | IT Consulting | ייעוץ IT | ייעוץ בתחום IT (לא ביצוע בפועל - מכרזים, וכד') |
| Hardware Maintenance | Hardware Maintenance | תחזוקת חומרה | תחזוקת חומרה |
| Infrastructure Projects | Consolidation/virtualization/ hardware integration projects | קונסולידציה/ וירטואליזציה/ פרוייקט תשתיות חומרה | פרוייקטי תשתיות |
| | software infra integration projects | תשתיות תוכנה | |
| | Data Center Environment | אולם מחשב | |
| | other | אחר | |
| Project Services | Project Management Office | ניהול פרויקט - PMO | שירותים פרויקטאליים (באחריות הספק) |
| | Q/A & Testing | בדיקות, QA | |
| | Rollout/Hatmaa | הטמעה | |
| | other | אחר | |

We rank VENDORS by
REVENUE
and
CLIENT MINDSHARE

All amounts in M \$ USD



IT Consulting Market



| 2011 | | 2012 | | 2013 | |
|------|-------|------|--------|------|-------------------------|
| 82.0 | 4.88% | 86.0 | 10.47% | 95.0 | IT Consulting/ Analysts |
| 82.0 | 4.88% | 86.0 | 10.47% | 95.0 | total |

We rank VENDORS by
REVENUE
 and
CLIENT MINDSHARE

All amounts in M \$ USD



Infrastructure Services Market



| 2011 | | 2012 | | 2013 | |
|-------|--------|-------|--------|-------|--|
| 150.0 | -2.67% | 146.0 | -2.74% | 142.0 | Hardware Maintenance |
| 45.0 | 11.11% | 50.0 | 20.00% | 60.0 | Data Center Environment |
| 90.0 | 3.33% | 93.0 | 9.68% | 102.0 | software & application integration & ALM |
| 145.0 | 4.83% | 152.0 | 8.55% | 165.0 | Consolidation/virtualization/hardware integration projects |
| 430.0 | 2.56% | 441.0 | 6.35% | 469.0 | total |

We rank VENDORS by
REVENUE
and
CLIENT MINDSHARE

All amounts in M \$ USD

We rank VENDORS by
REVENUE
and
CLIENT MINDSHARE

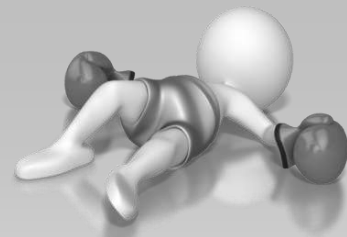

Hardware Maintenance

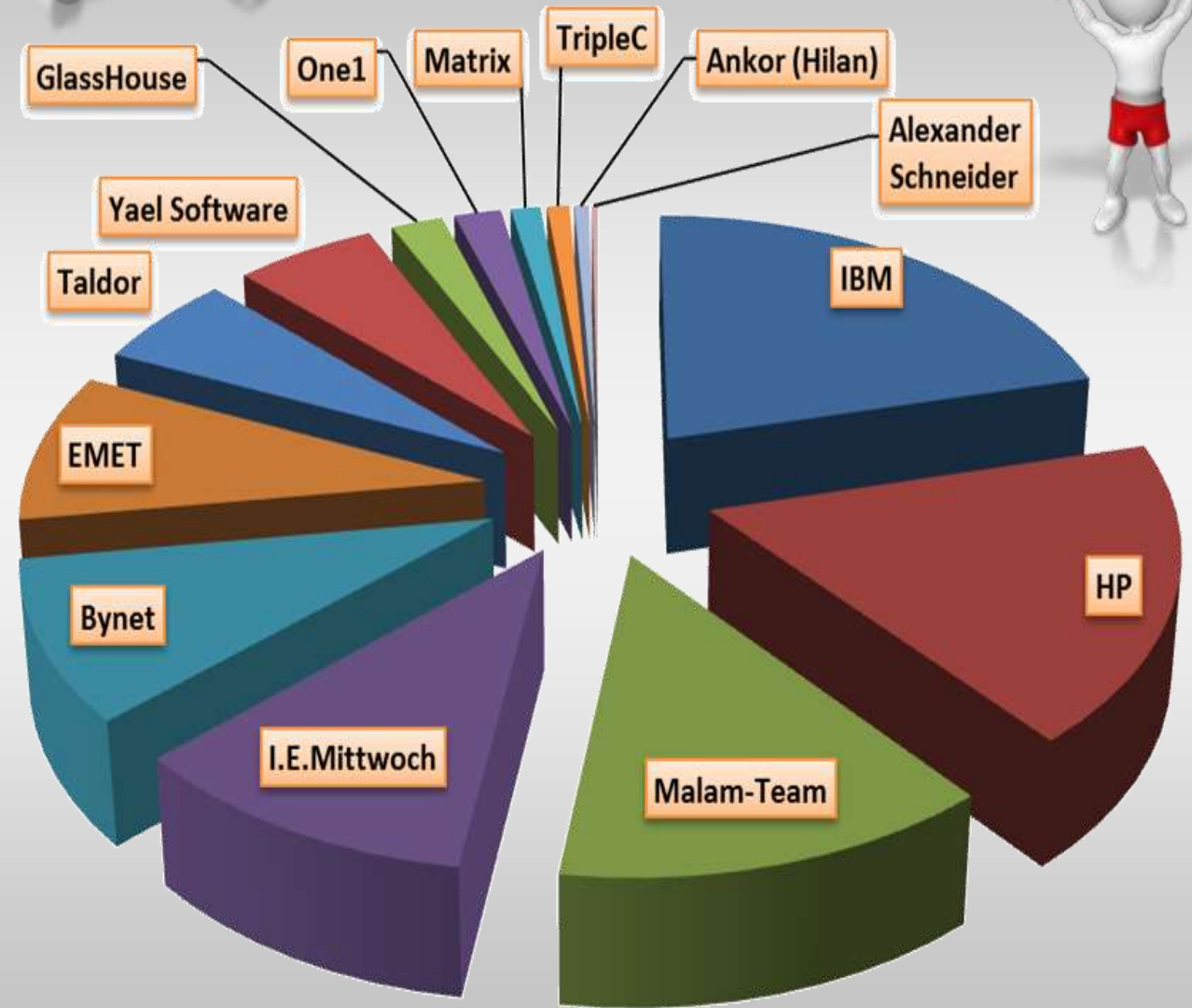

Comparison Infrastructure Integration Market 2012

Consolidation/virtualization/networking/hwre integration & monitoring

- Partner/012
- AVCS
- Netvision/ Cellcom
- NGSoft
- Comm IT
- Aman Computers
- We (Hilan)
- Headon
- Magalcom
- Minicom
- SQLink
- Microsoft
- One1
- BenefIT
- HDS
- Yside
- TripleC
- Neway
- 2Bsecure
- Ankor (Hilan)
- doITwise



- Dor -IT
- HMS
- Liacom
- techmind
- Simplementia
- penguinIT
- ELAD
- Ardom
- openstorage
- SteerU
- elk-group
- Centerity
- ITassist
- Afek Systems

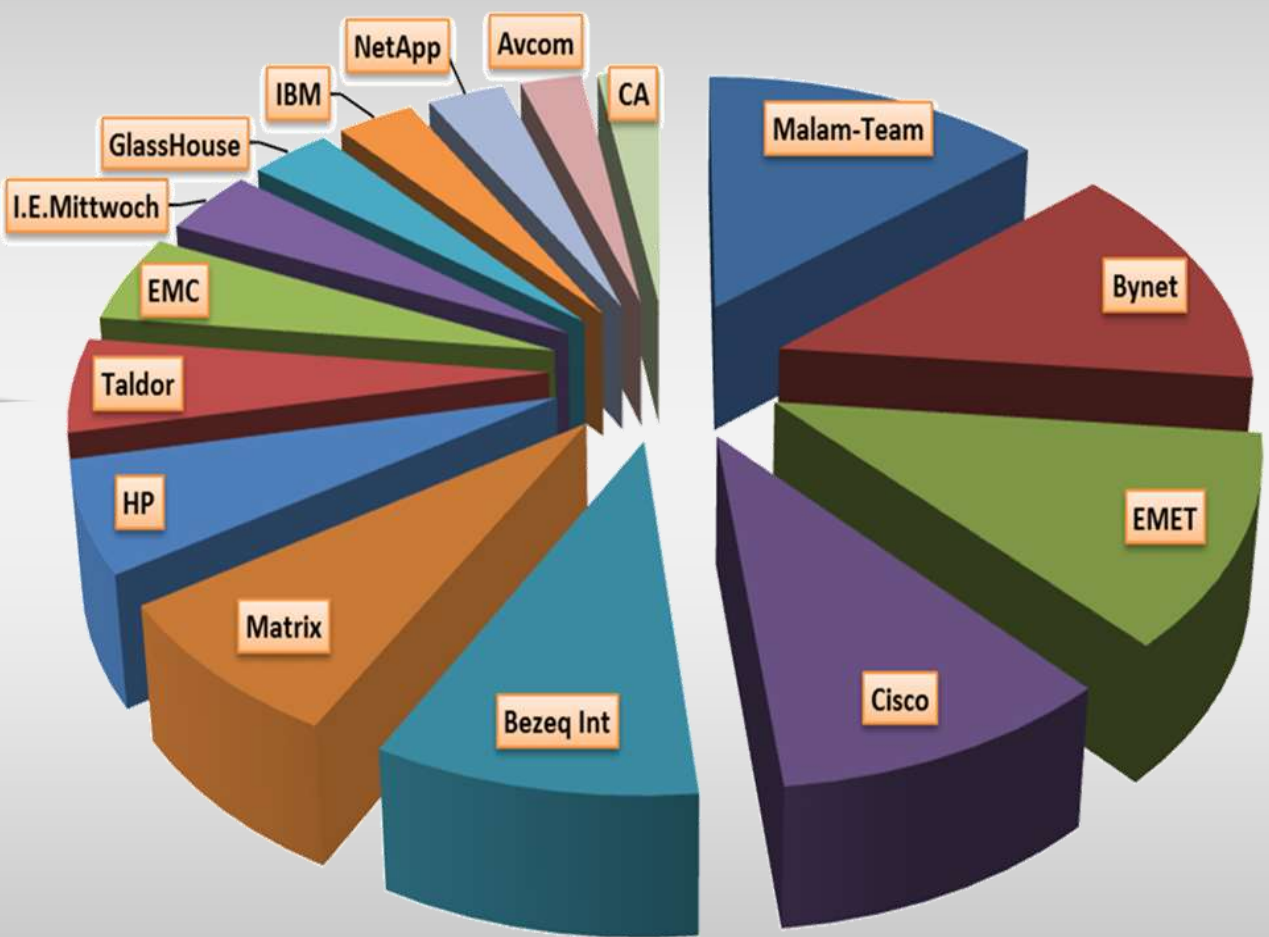

Comparison Infrastructure Services Market 2 2012

Software Infrastructure, SOA & ALM Integration

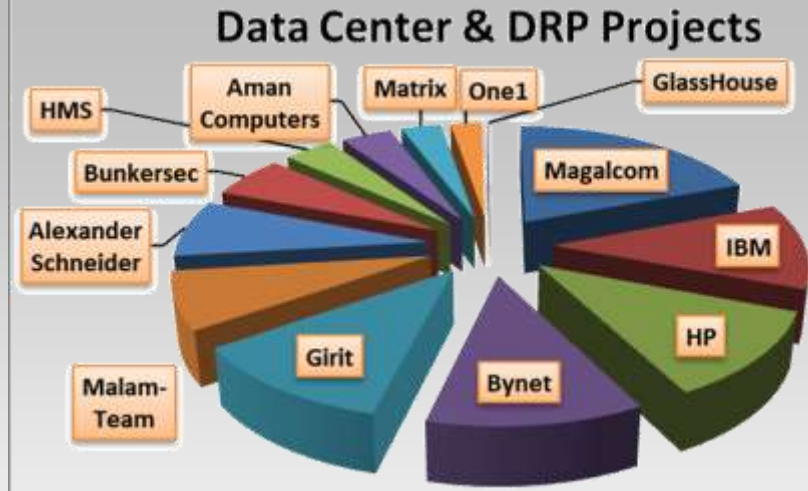
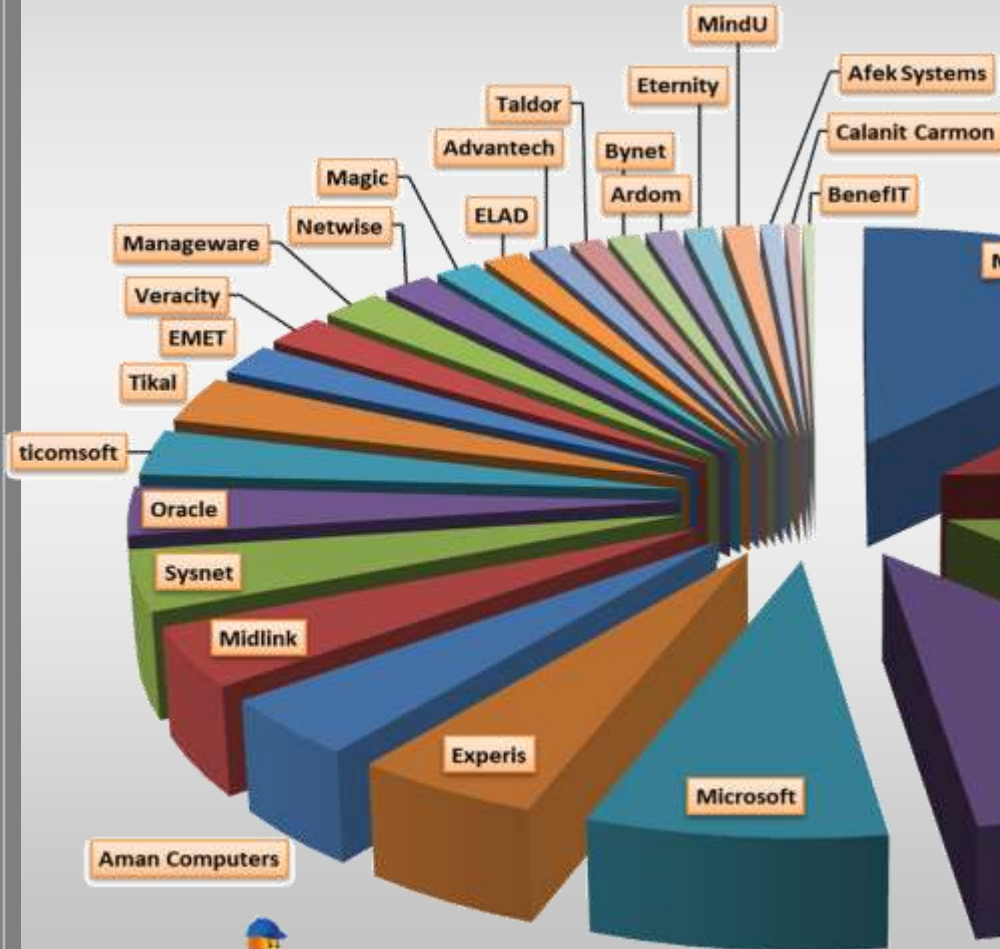

Project Services Market

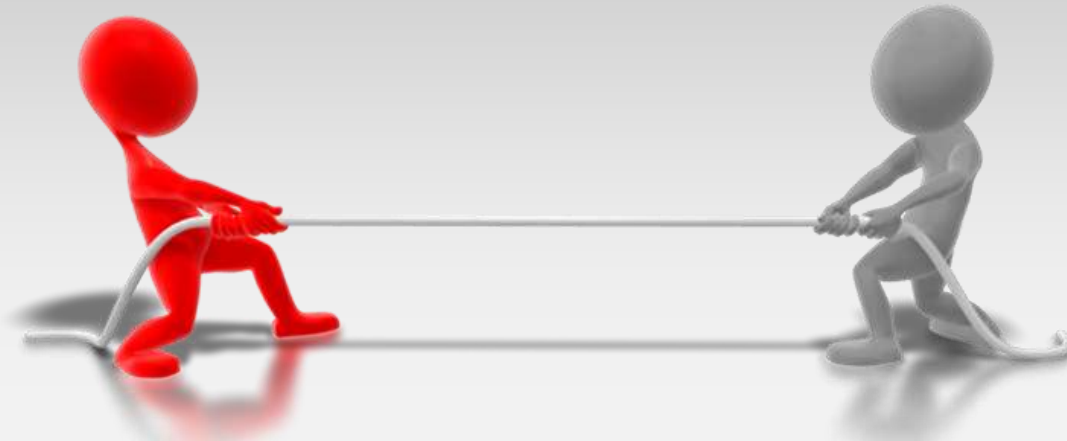

| 2011 | | 2012 | | 2013 | |
|--------------|--------------|--------------|--------------|--------------|---------------------------|
| 90.0 | 5.56% | 95.0 | 7.37% | 102.0 | Q/A & Testing |
| 52.0 | 5.77% | 55.0 | 9.09% | 60.0 | Roll-out Hatmaa |
| 20.0 | 10.00% | 22.0 | 9.09% | 24.0 | Project Management Office |
| 162.0 | 6.17% | 172.0 | 8.14% | 186.0 | total |

We rank VENDORS by
REVENUE
 and
CLIENT MINDSHARE

All amounts in M \$ USD



Comparison Project Services Market 2012

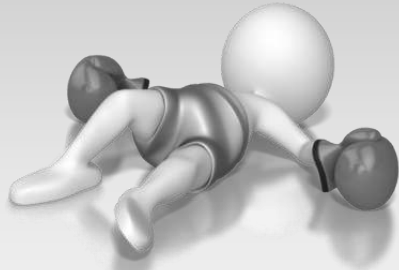

PMO Implementation & Services

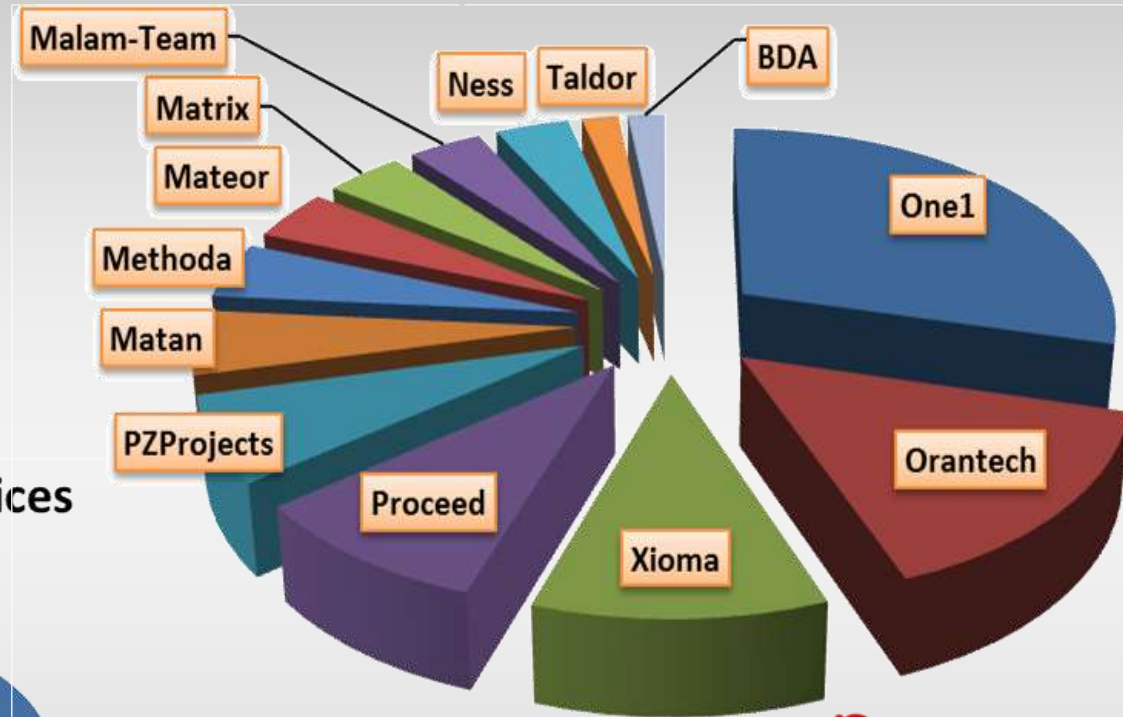

Roll-out/Hatmaa Services

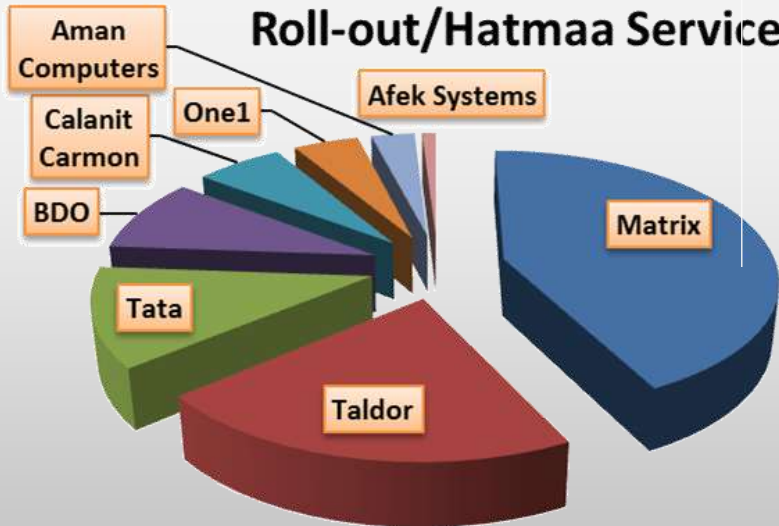

We rank VENDORS by
REVENUE
and
CLIENT MINDSHARE

Q/A Testing Services

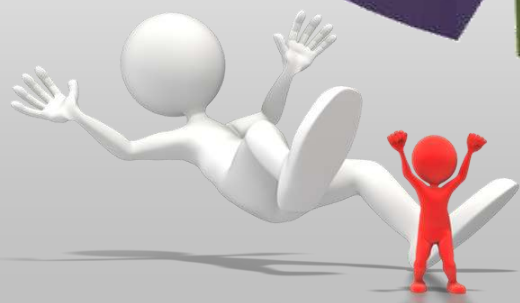
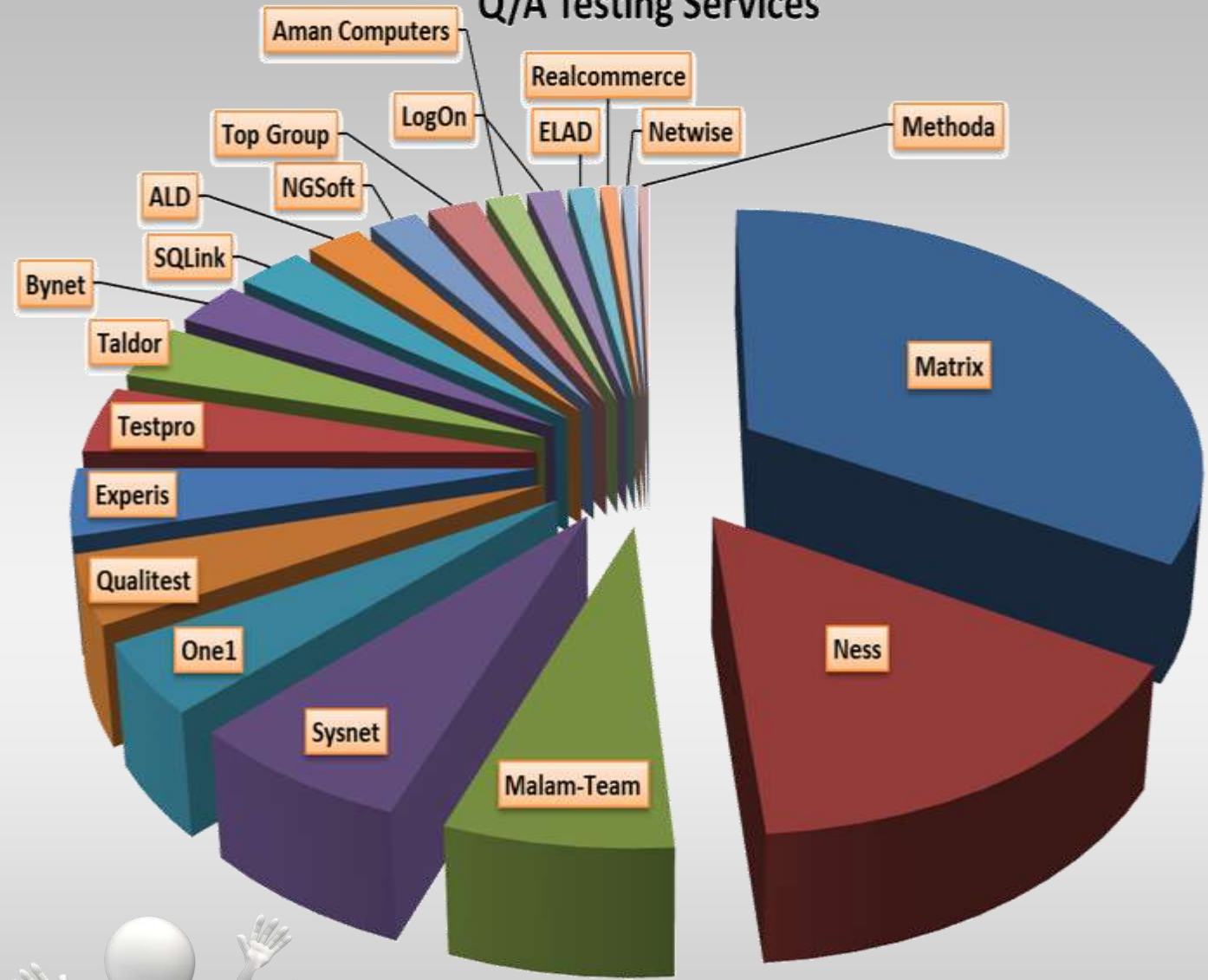

Value Added Services Categories 2

| | | | |
|-------------------|---|---|-------------------|
| Development | ERP | ERP | שירותי פיתוח |
| | CRM | CRM | |
| | knowledge management (ECM, SP, BPM, Portals) | ניהול ידע (תוכן, SP, פורטלים, BPM) | |
| | .NET based without internet | דוט נט ללא אינטרנט ומובייל | |
| | java based without internet | Java ללא אינטרנט ומובייל | |
| | Web/internet | אתרי אינטרנט | |
| | Social and eBiz applications | מדיה חברתית/ ביזנס מקוון | |
| | Mobile, MDM | פיתוח מובייל וניהול מכשירי מובייל | |
| | User Interface Design | עיצוב ממשק משתמש | |
| | BI/DW/EPM/Data Management | מחסיני נתונים, BI, ניהול ביצועי הארגון, ניהול נתונים | |
| | application integration | קישוריות SOA | |
| | mainframe/AS400 | mainframe\AS400 | |
| | core vertical development | פיתוח אפליקציות ליבה/ ורטיקליות | |
| | Printing | הדפסה | |
| | Migrations | הסבות של מערכות | |
| | Archiving | ארכוב | |
| other | אחר | | |
| Talent Skill Mgmt | IT Training inhouse | הדרכה באתר הלקוח | הדרכת IT |
| | IT Training at Vendor | הדרכה באתר הספק | |
| VoIP/Call Centers | VoIP/telephony | טלפוניה/ VOIP | VoIP/Call Centers |
| | VoIP/call center | call center \VOIP | |

We rank VENDORS by
REVENUE
and
CLIENT MINDSHARE

All amounts in M \$ USD



Software Development Services Market

| 2011 | | 2012 | | 2013 | |
|--------------|--------------|--------------|---------------|--------------|-----------------------------------|
| 150.0 | 6.67% | 160.0 | 13.75% | 182.0 | ERP |
| 45.0 | 4.44% | 47.0 | 10.64% | 52.0 | CRM |
| 89.0 | 3.37% | 92.0 | 13.04% | 104.0 | KM,ECM,SP,BPM,others |
| 85.0 | 7.06% | 91.0 | 20.88% | 110.0 | .NET (XRM) based without internet |
| 37.0 | 5.41% | 39.0 | 5.13% | 41.0 | Java based without internet |
| 50.0 | 6.00% | 53.0 | 22.64% | 65.0 | Web/internet |
| 15.0 | 33.33% | 20.0 | 35.00% | 27.0 | social & e-biz |
| 25.0 | 24.00% | 31.0 | 29.03% | 40.0 | Mobile/MDM |
| 47.0 | -14.89% | 40.0 | -12.50% | 35.0 | Legacies/mainframe |
| 95.0 | 10.53% | 105.0 | 23.81% | 130.0 | BI/DW/EPM/Data Management |
| 58.0 | 3.45% | 60.0 | 20.00% | 72.0 | core/vertical |
| 20.0 | 5.00% | 21.0 | 19.05% | 25.0 | output mgmt/print mgmt |
| 18.0 | 11.11% | 20.0 | 45.00% | 29.0 | User Interface Design |
| 25.0 | 8.00% | 27.0 | 18.52% | 32.0 | Migrations/ others |
| 759.0 | 6.19% | 806.0 | 17.12% | 944.0 | totals |

We rank VENDORS by
REVENUE
and
CLIENT MINDSHARE

All amounts in M \$ USD



Comparison

Software Development Market 2012



ERP based projects

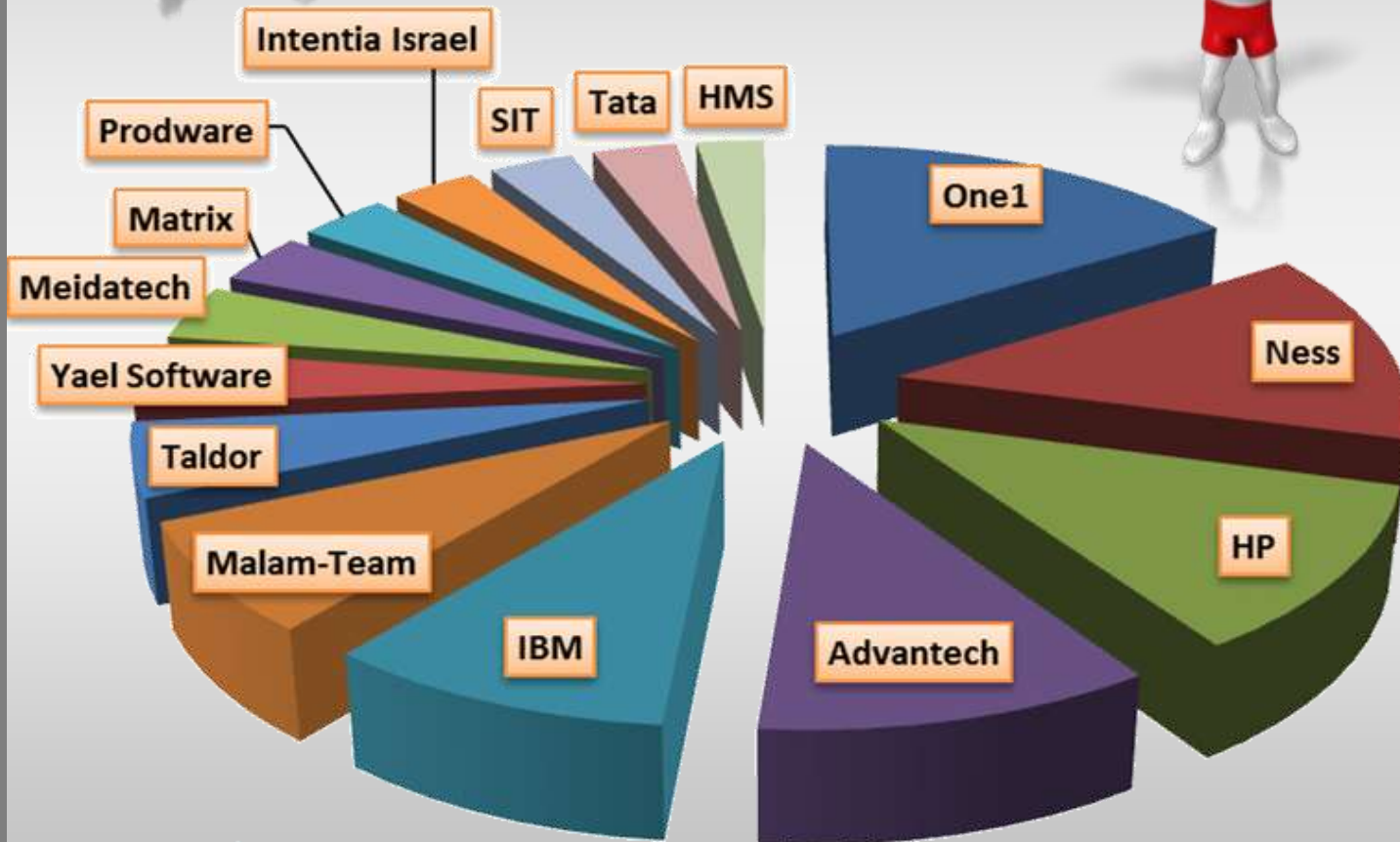

| |
|----------------|
| FBC |
| Almog |
| Aman Computers |
| Eshbel |
| Kav marachot |
| Menahel4U |
| Raan |
| Rels |
| Todan |
| Unitask |
| Ziv systems |
| Maxoft |
| Xioma |
| Axperts |
| Accenture |
| C.BIT |
| ELAD |
| Pilat |
| Aviv |
| Afek Systems |
| Pisga |
| Anagal |
| Tulip |

Comparison

Software Development Market 2 2012

CRM Projects

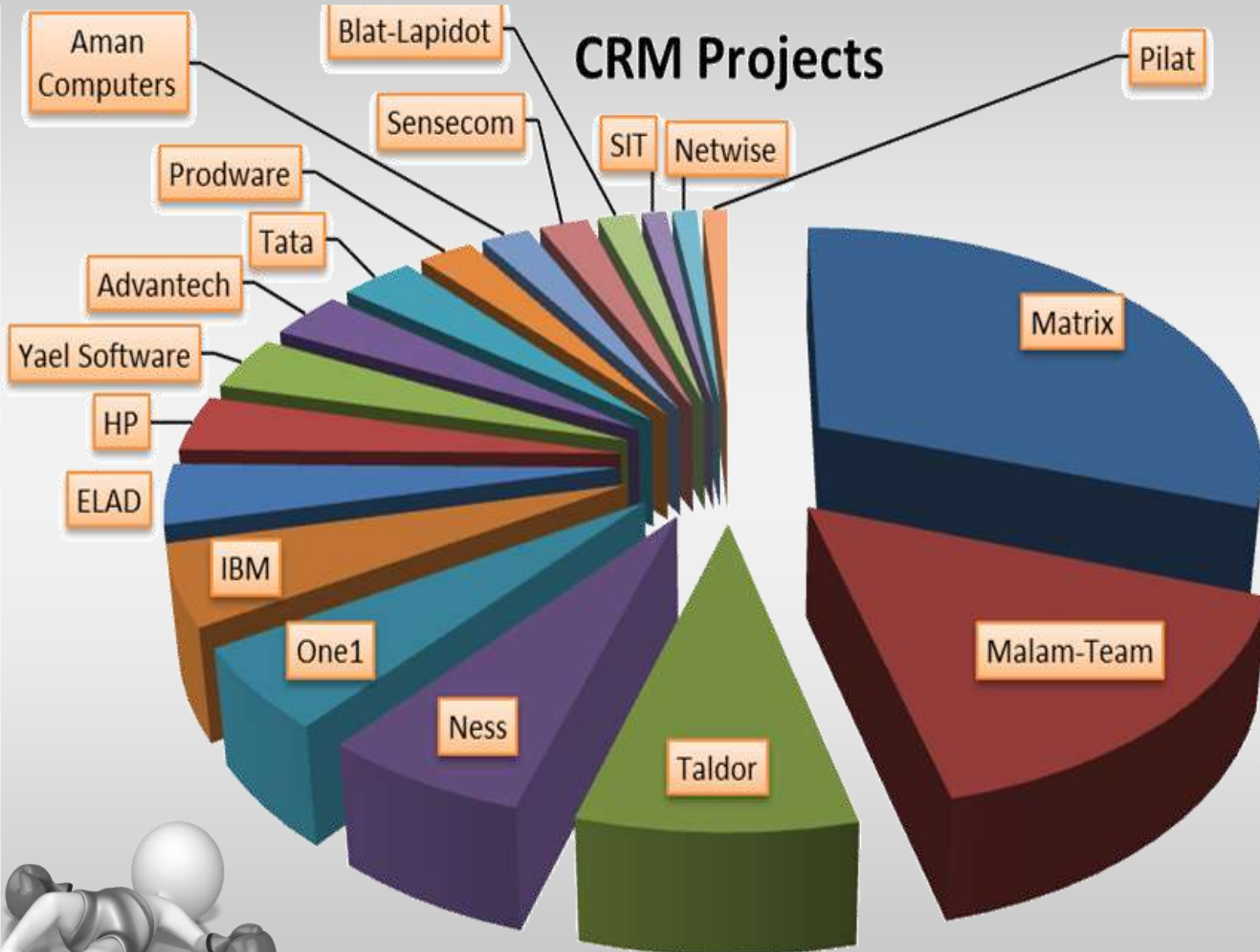

| |
|--------------|
| Meidatech |
| Kav marachot |
| Maxoft |
| Raan |
| Anagal |
| CEMax |
| Eshbel |
| Unitask |
| IT Navigator |
| ManofIT |
| Pisga |
| IntegrITy |

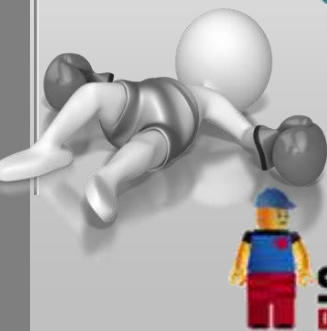

Comparison

Software Development Market 3 2012

Knowledge Management (ECM, SP, BPM, Portals)

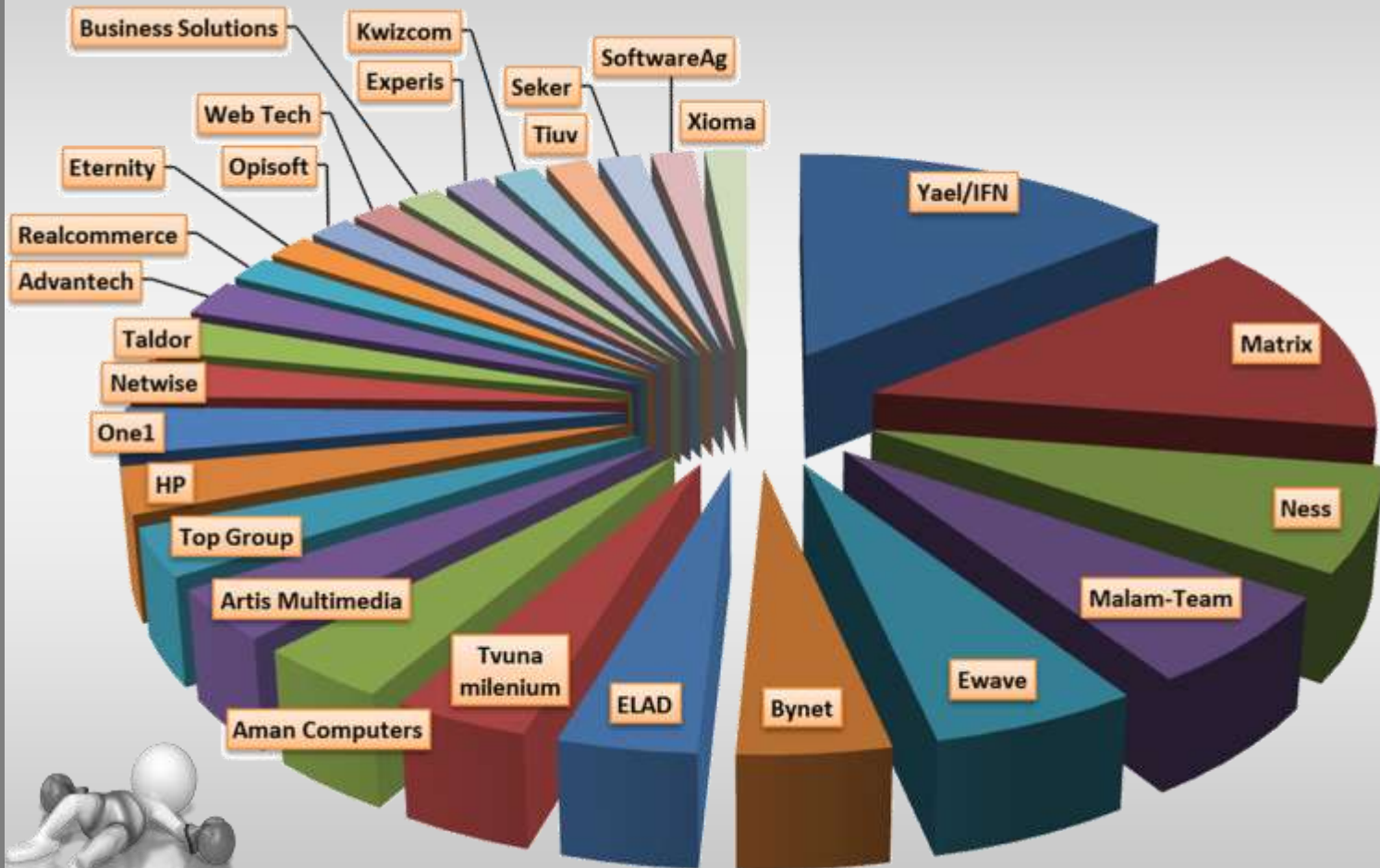

| |
|--------------------|
| PNMsoft |
| Hevra Le Automazia |
| Moding |
| Know-edge |
| ProcessGene |
| C-soft |
| Matan |
| Methoda |
| IntegrITy |
| BluePhoenix |



We rank VENDORS by
REVENUE
and
CLIENT MINDSHARE

.NET (XRM) without Internet

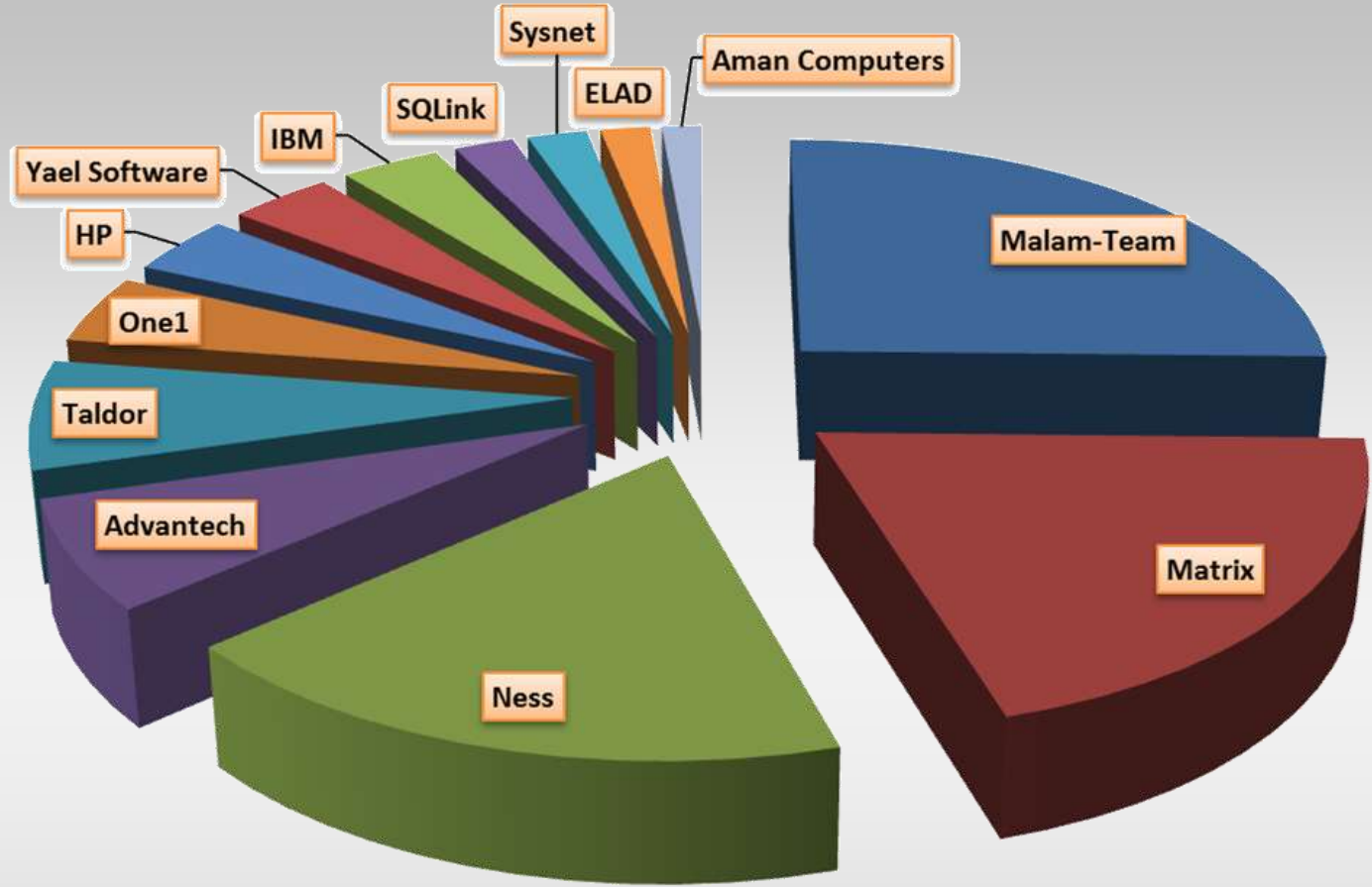

- I.E.Mittwoch
- Tvuna milenium
- Netwise
- Afek Systems
- Experis
- Hevra Le Automazia
- Almog
- SIT

- Top Group
- Bynet
- DBbest
- Renaissance
- Matan
- Calanit Carmon

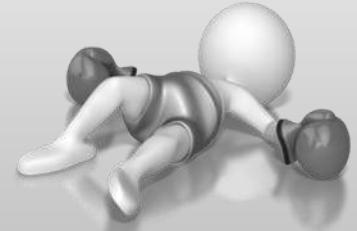

Comparison

Software Development Market 4 2012

JAVA (without internet) Development

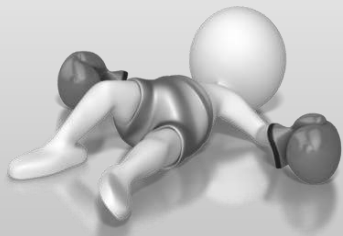
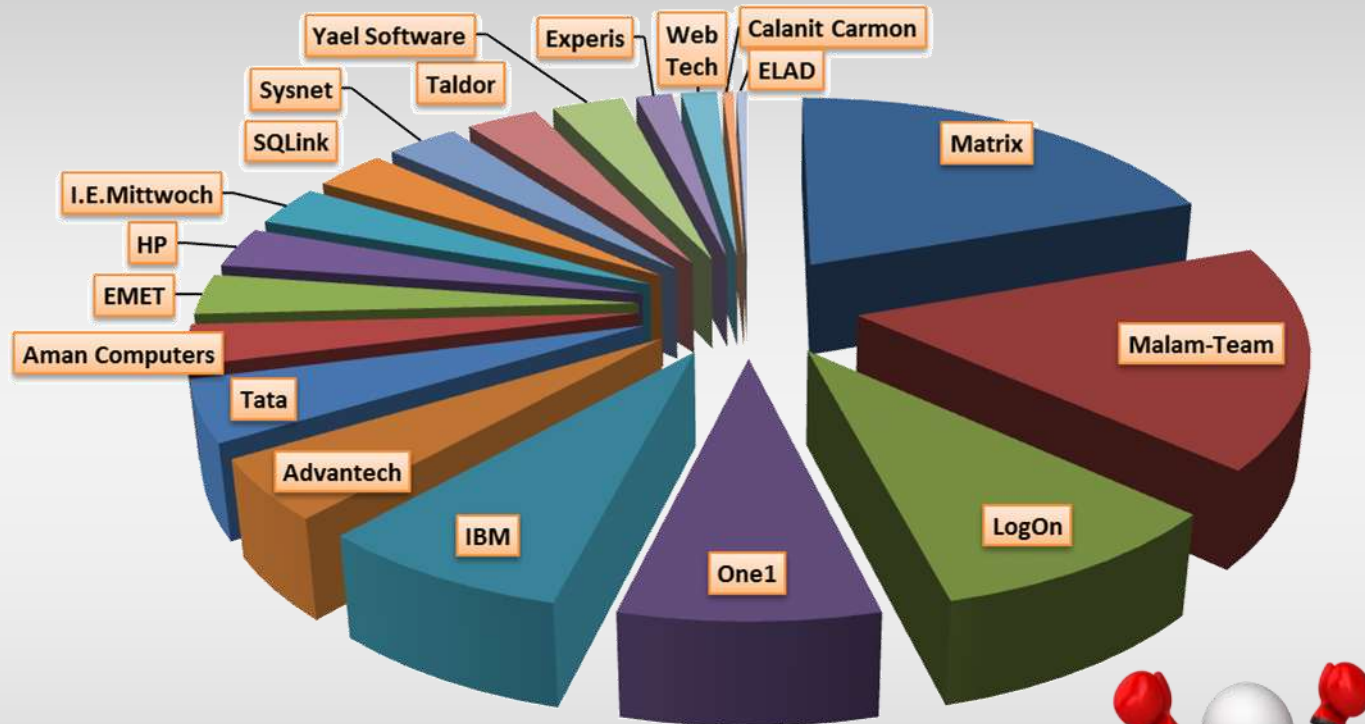

Comparison

Software Development Market 5 2012



Web/Internet Development

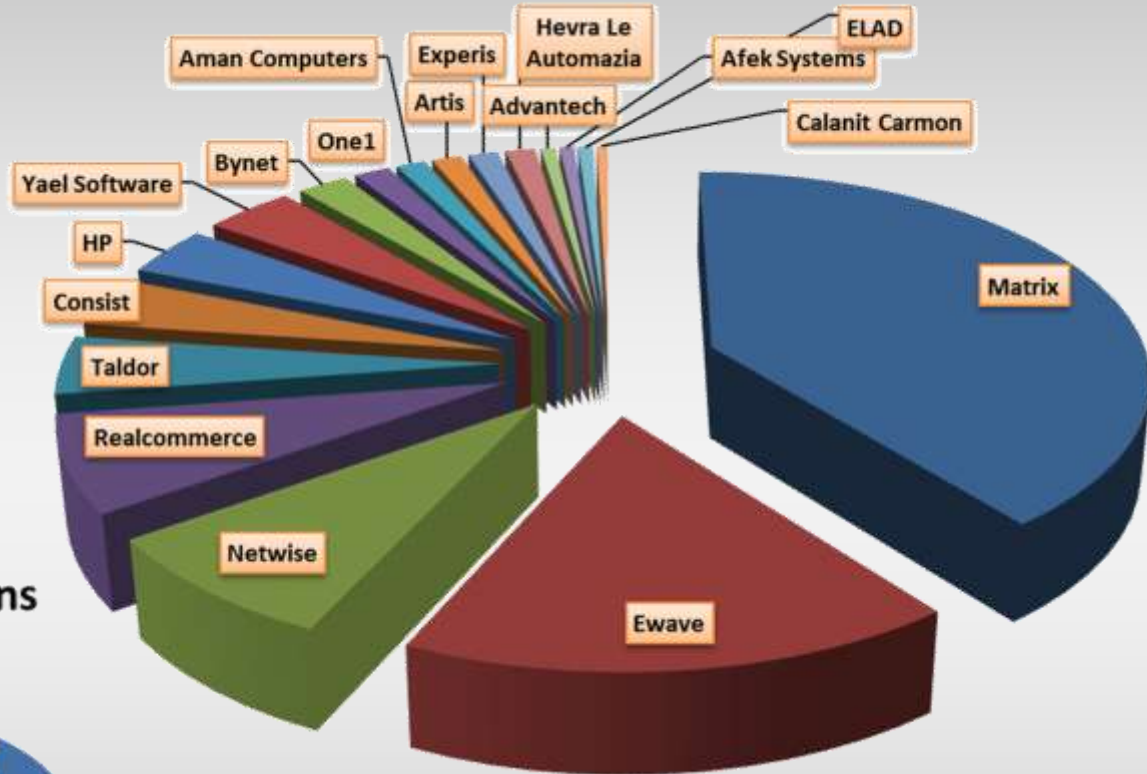

Social & e-bizz Applications



We rank VENDORS by
REVENUE
and
CLIENT MINDSHARE

Mobile Development

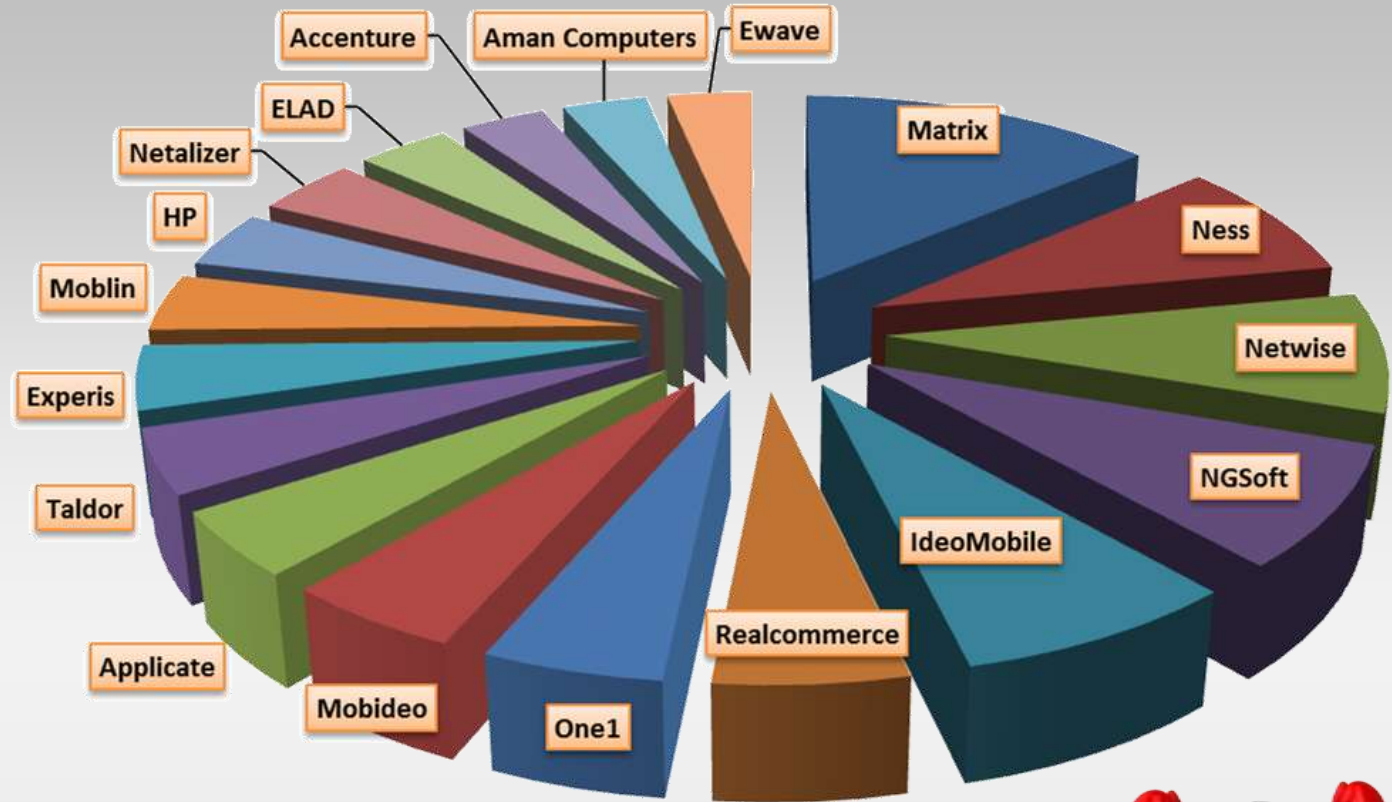

User Interface Projects

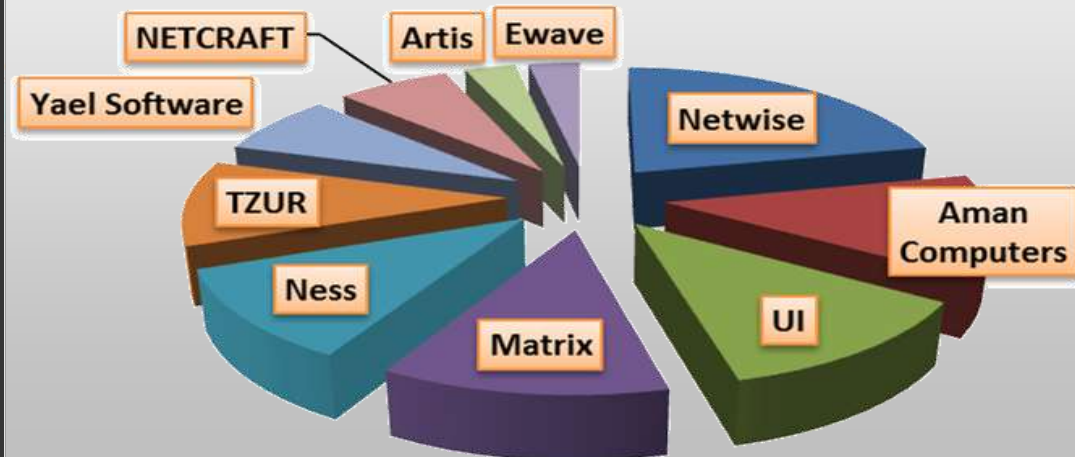

Comparison

Software Development Market 6 2012

BI/DW/EPM/Data Management

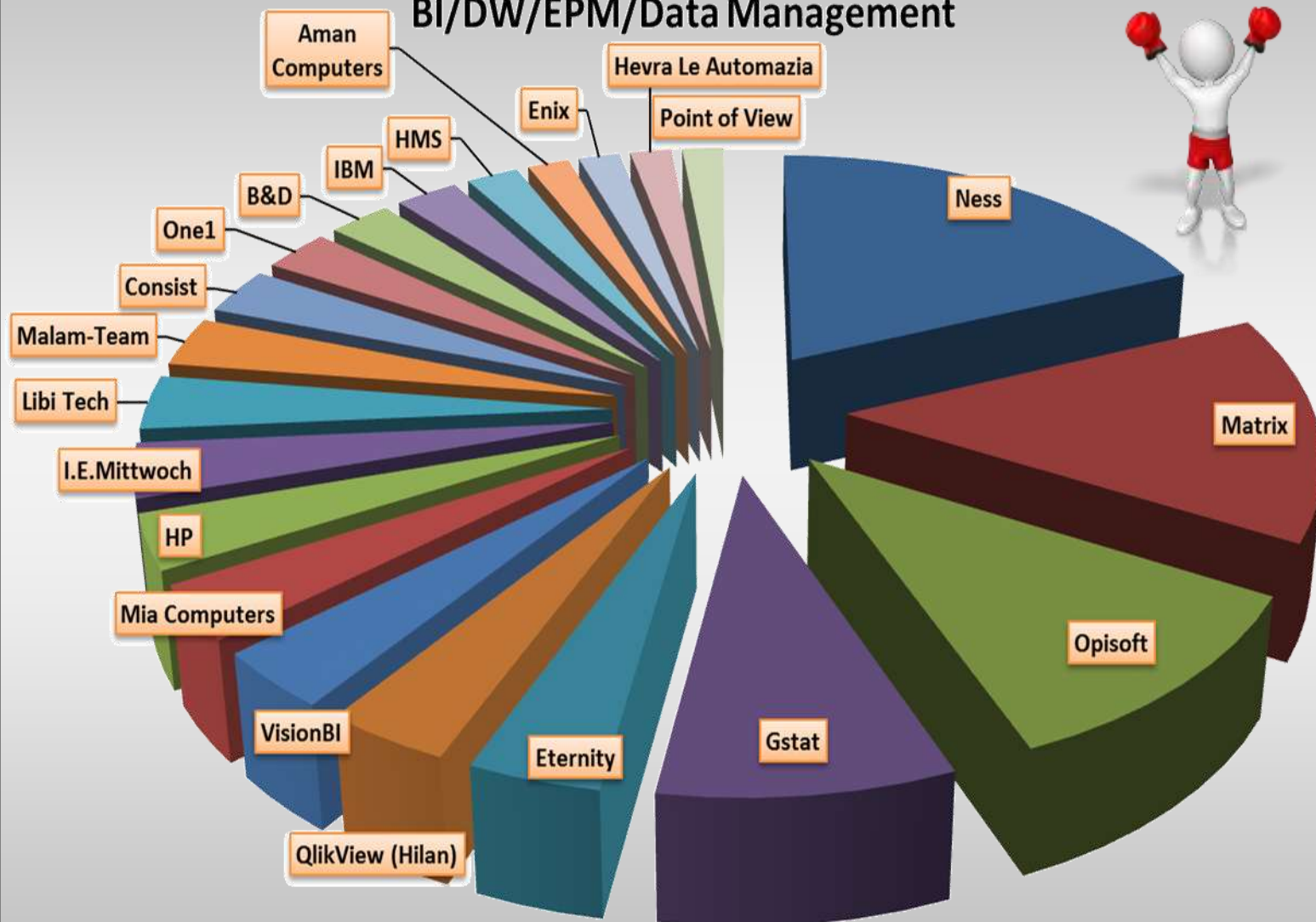

| |
|----------------|
| Blconix |
| Citrine BI |
| Data Cube |
| Active View |
| Yael Software |
| Experis |
| Normative |
| Taldor |
| BICS |
| Bynet |
| Matan |
| SQLink |
| SIT |
| Anagal |
| SkyWin |
| Xioma |
| Orantech |
| WinIT |
| Calanit Carmon |
| DBbest |
| Netwise |
| Pilat |
| Afek Systems |
| ELAD |

Training Services Market



| 2011 | | 2012 | | 2013 | |
|-------|-------|-------|--------|-------|----------|
| 105.0 | 2.86% | 108.0 | 18.52% | 128.0 | training |
| 105.0 | 2.86% | 108.0 | 18.52% | 128.0 | totals |

We rank VENDORS by
REVENUE
 and
CLIENT MINDSHARE

All amounts in M \$ USD



We rank VENDORS by
REVENUE
and
CLIENT MINDSHARE

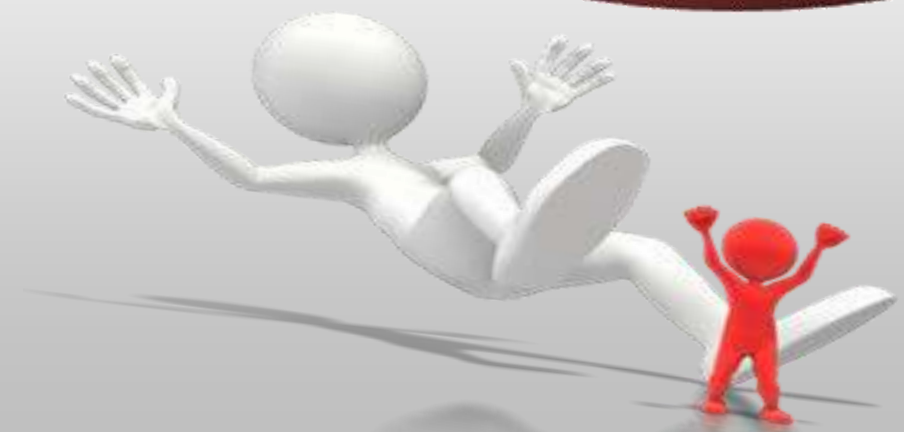
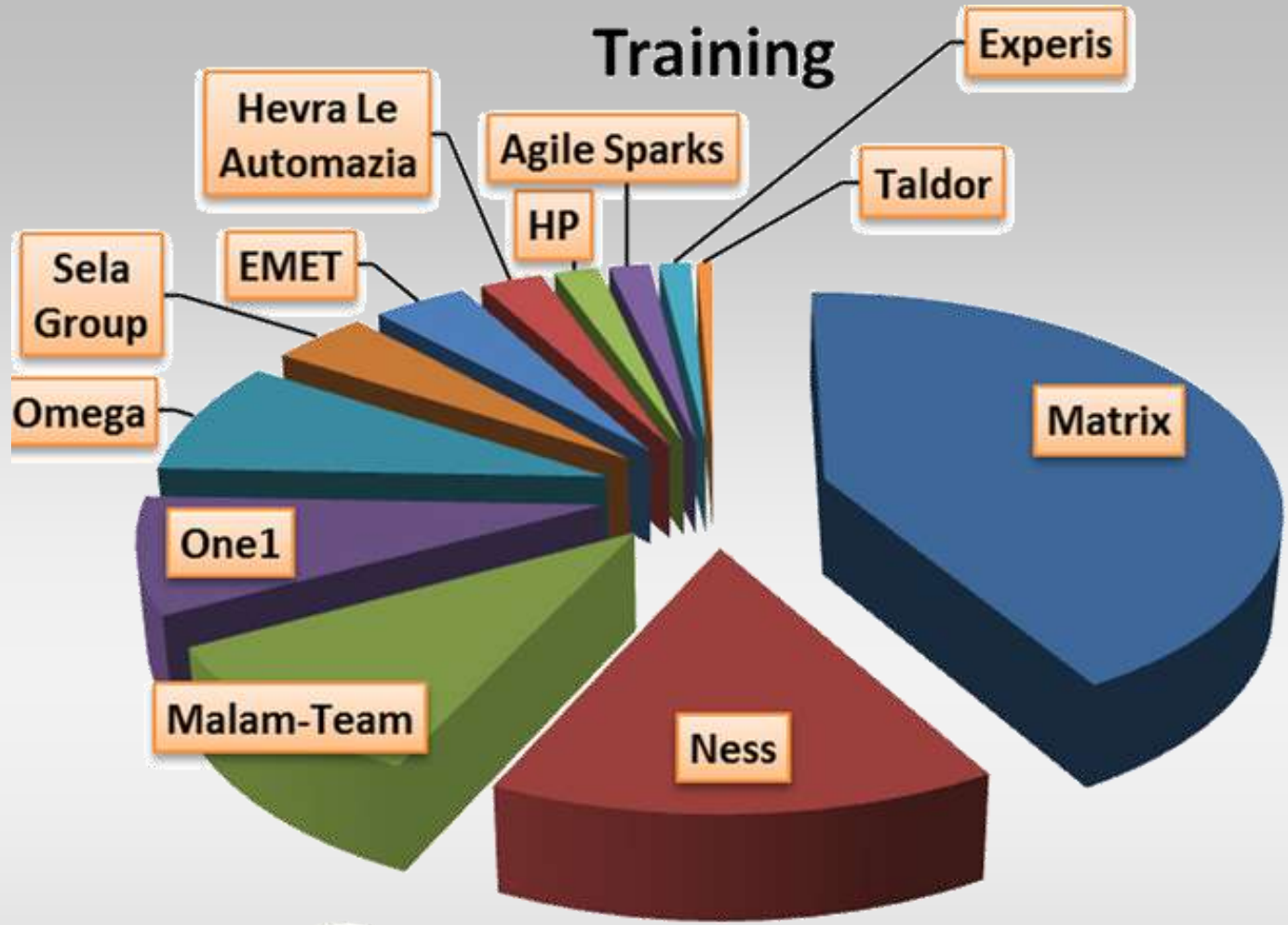

VoIP Services Market

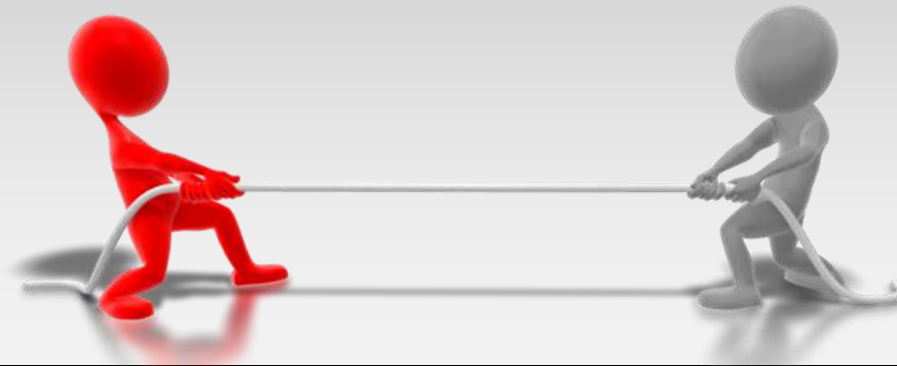

| 2011 | | 2012 | | 2013 | |
|------|-------|------|--------|------|--------------|
| 50.0 | 2.00% | 51.0 | 7.84% | 55.0 | VoIP |
| 32.0 | 9.38% | 35.0 | 14.29% | 40.0 | call centers |
| 82.0 | 4.88% | 86.0 | 10.47% | 95.0 | totals |

We rank VENDORS by
REVENUE
 and
CLIENT MINDSHARE

All amounts in M \$ USD



Comparison VoIP Market 2012

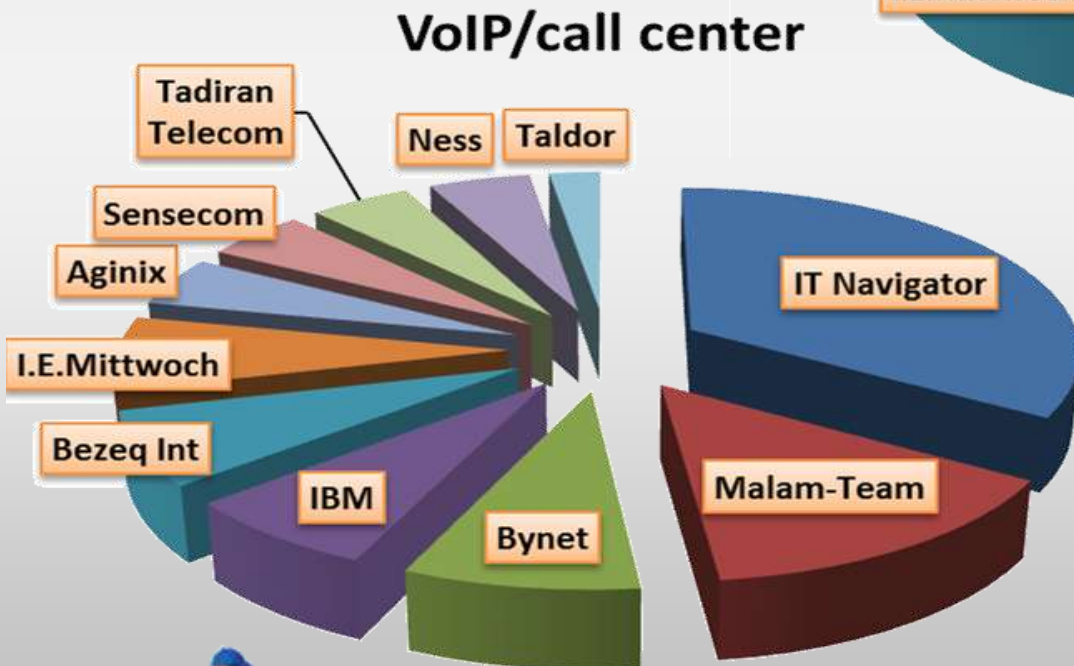
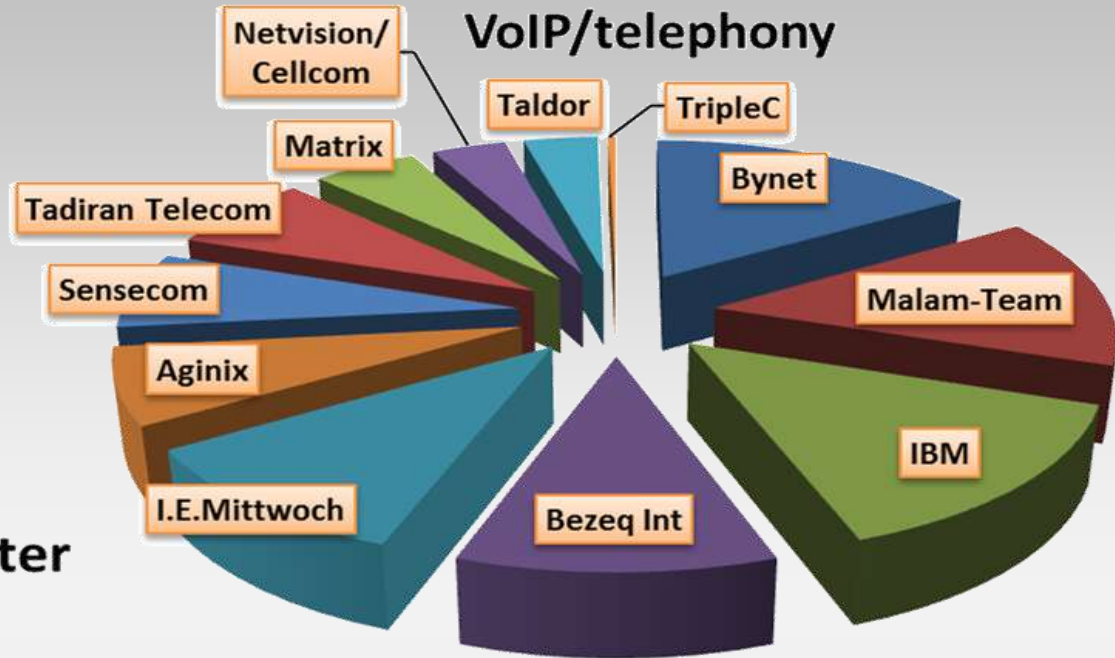
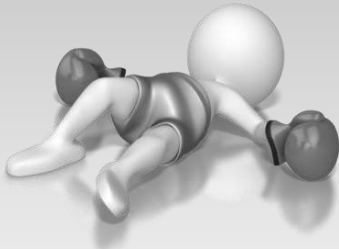

Value Added Services Categories 3

| | | | |
|------------------------------|---|--|-------------------------|
| Governance & Risk Management | auditing | ביקורת/רגולציה | ניהול סיכונים, רגולציות |
| | Governance & Risk Management | ניהול סיכונים | |
| | risk assessment/ penetration tests | הערכת סיכונים ומבדקי חדירה | |
| | security projects | אבטחת מידע | |
| | other | אחר | |
| OUTSOURCING SERVICES | "off site" data center/hosting (finger only services) | מרכז מחשוב חיצוני, מחוץ לבית הלקוח (אירוח ל-DRP) | מיקור חוץ |
| | "off site" data center - full service (operational/DRP) | מרכז מחשוב חיצוני, מחוץ לבית הלקוח באחריות מלאה של ספק | |
| | Call Centers/Help Desk | שירותי תמיכה בלקוחות \ call centers | |
| | Complete outsourcing | מיקור חוץ מלא | |
| | application outsourcing | מיקור חוץ אפליקטיבי | |
| | other | אחר | |
| | Infrastructure Outsourcing | managed infrastructure services | מיקור חוץ כולל לתשתיות |
| storage management | | לתחום האחסון | |
| DBA services | | לשירותי DBA | |
| security services | | לשירותי אבטחת מידע | |
| other | | אחר | |

We rank VENDORS by
REVENUE
and
CLIENT MINDSHARE

All amounts in M \$ USD



Governance, Risk, Regulation and Security Market



| 2011 | | 2012 | | 2013 | |
|-------|--------|-------|--------|-------|---|
| 40.0 | 5.00% | 42.0 | 19.05% | 50.0 | Governance & Risk Management (also BCP) |
| 20.0 | 5.00% | 21.0 | 14.29% | 24.0 | Risk assesment & penetration tests |
| 15.0 | 20.00% | 18.0 | 5.56% | 19.0 | Security Auditing |
| 120.0 | 4.17% | 125.0 | 12.00% | 140.0 | Security Projects |
| 195.0 | 5.64% | 206.0 | 13.11% | 233.0 | total risk |

We rank VENDORS by
REVENUE
 and
CLIENT MINDSHARE

All amounts in M \$ USD



We rank VENDORS by
REVENUE
and
CLIENT MINDSHARE

Governance & Risk Management

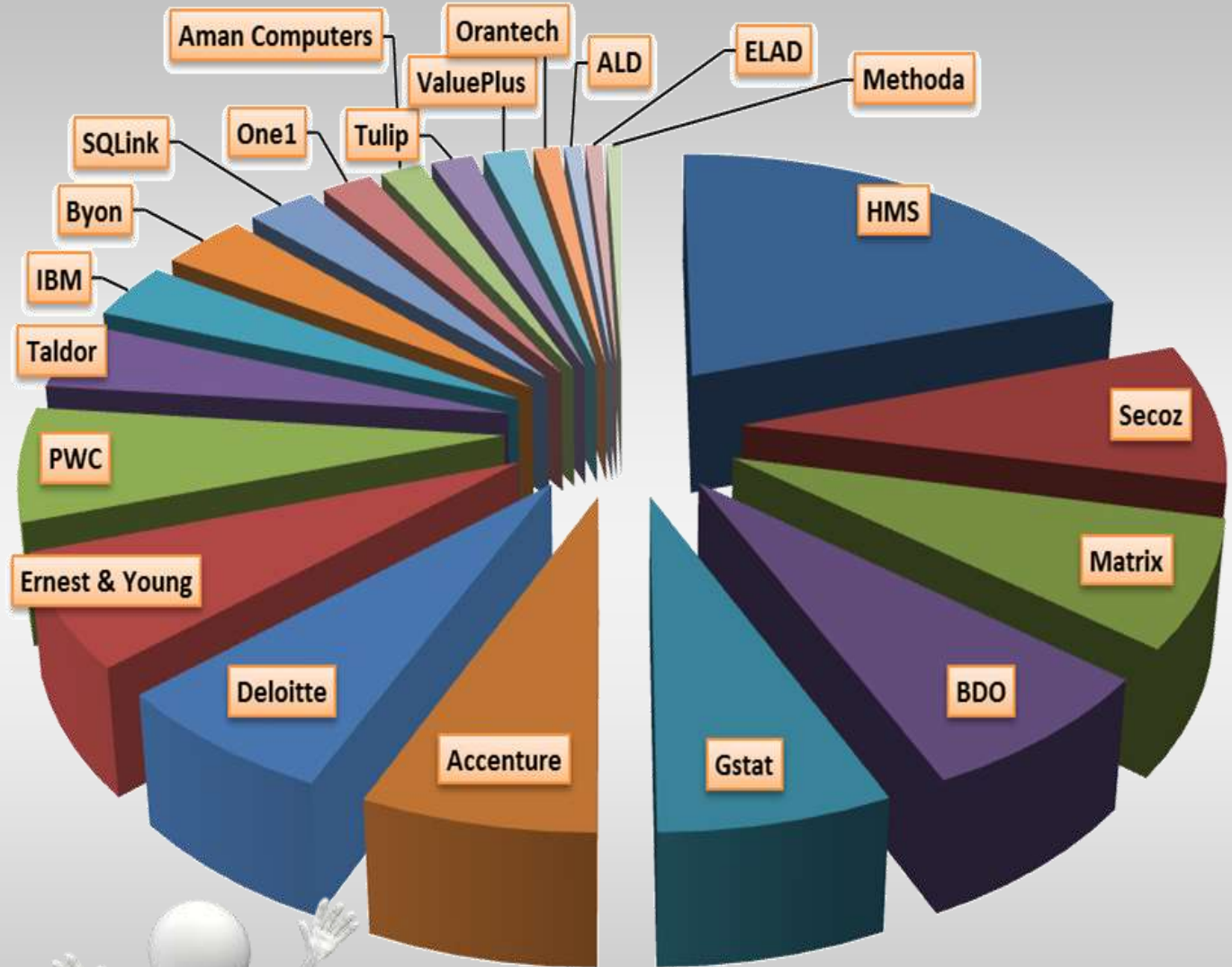

Comparison Security Projects Market 2012

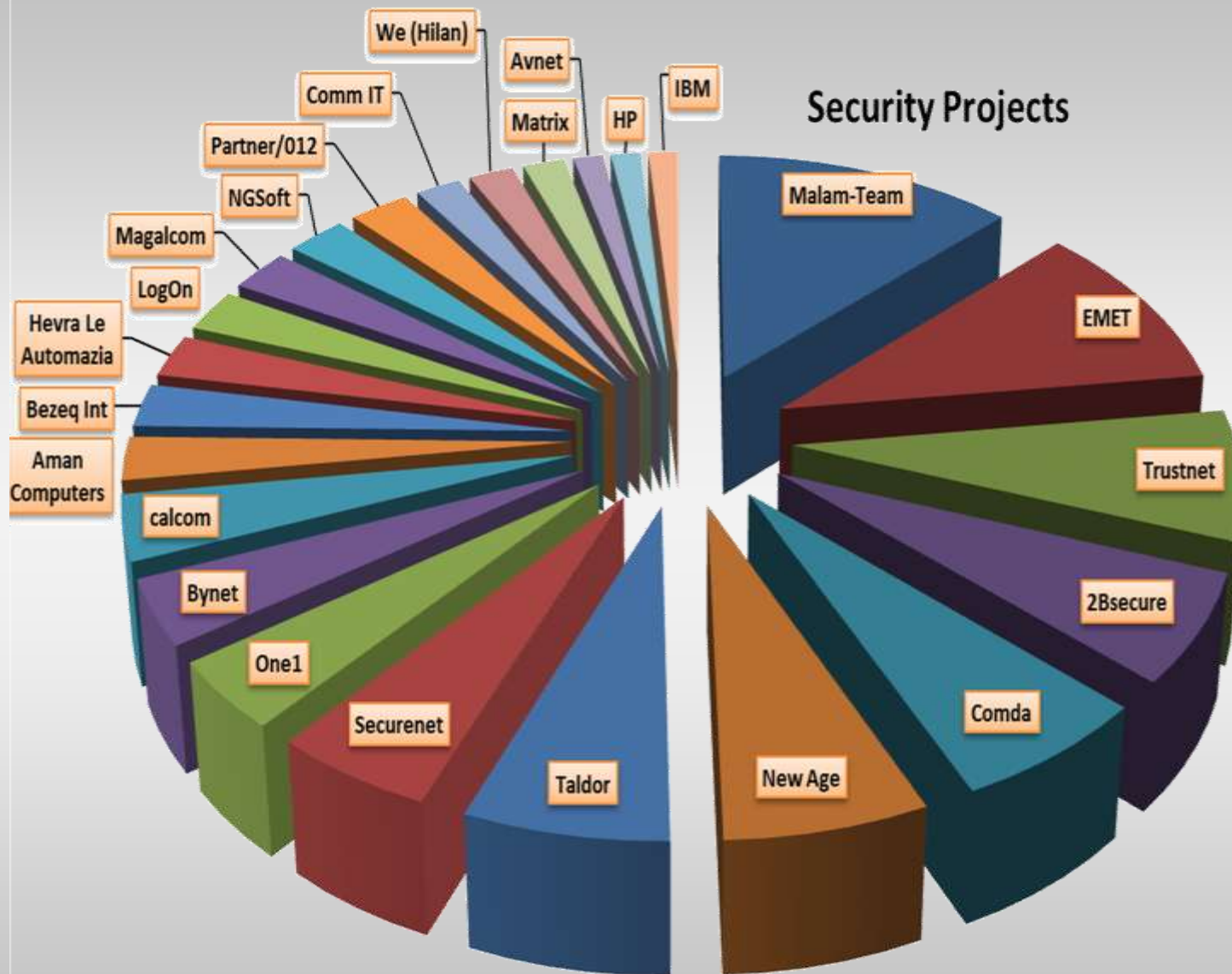

Comparison Security Projects Market 2 2012

Risk Assessment & Penetration Tests

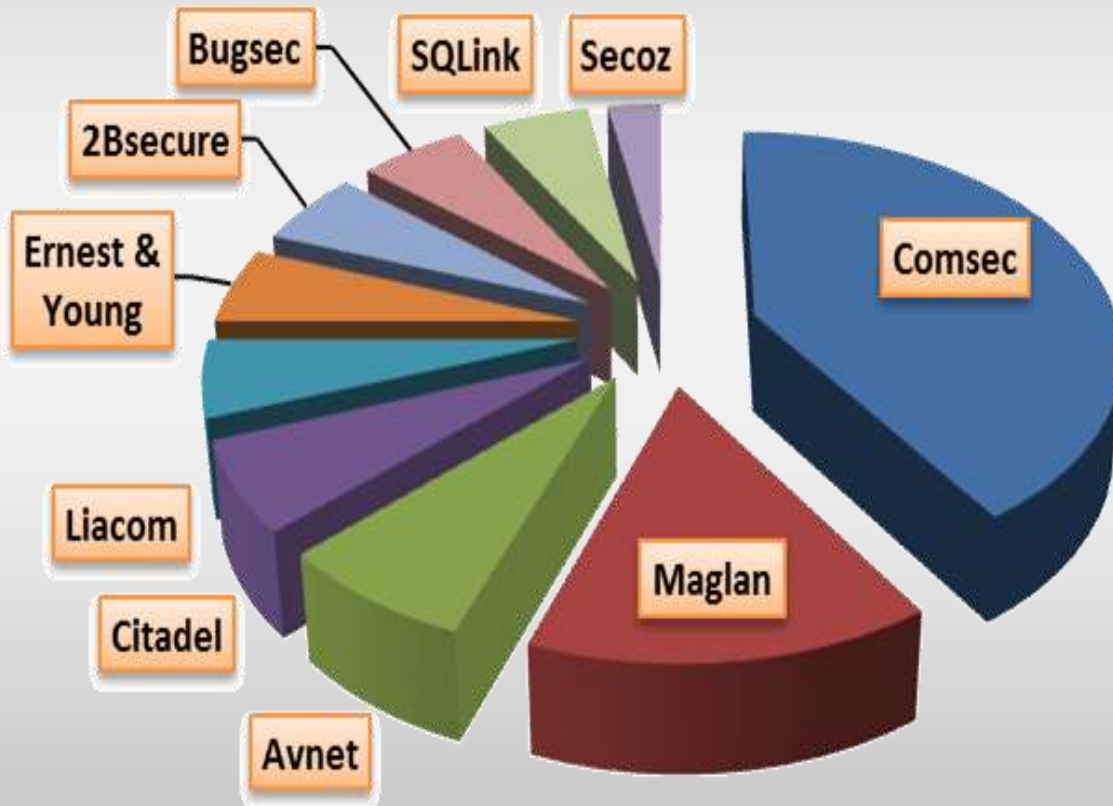

| |
|----------------|
| IPV Security |
| IPGroup |
| C4 |
| Partner/012 |
| Dor -IT |
| Brillix |
| Raz-Lee |
| Aman Computers |
| Comm IT |



Outsourcing Market



| 2011 | | 2012 | | 2013 | | |
|--------------|--------------|--------------|---------------|--------------|---|-------------------------|
| 50.0 | 4.00% | 52.0 | 7.69% | 56.0 | Archiving Services | |
| 50.0 | 4.00% | 52.0 | 15.38% | 60.0 | "off site" DC/finger services (hosting, real estate, etc) | |
| 40.0 | 25.00% | 50.0 | 10.00% | 55.0 | "off site" DC/full service/DRP | |
| 60.0 | 3.33% | 62.0 | 9.68% | 68.0 | call centers/help desk | |
| 160.0 | 1.25% | 162.0 | 4.94% | 170.0 | Complete outsourcing | |
| 42.0 | 9.52% | 46.0 | 13.04% | 52.0 | application outsourcing | |
| 40.0 | 5.00% | 42.0 | 7.14% | 45.0 | infrastructure outsourcing | Managed services |
| 15.0 | 20.00% | 18.0 | 16.67% | 21.0 | | storage |
| 32.0 | 12.50% | 36.0 | 8.33% | 39.0 | | DBA |
| 18.0 | 16.67% | 21.0 | 38.10% | 29.0 | | security |
| 32.0 | 6.25% | 34.0 | 17.65% | 40.0 | | printing/copying/faxing |
| 539.0 | 6.68% | 575.0 | 10.43% | 635.0 | totals | |

We rank VENDORS by
REVENUE
 and
CLIENT MINDSHARE

All amounts in M \$ USD



We rank VENDORS by
REVENUE
and
CLIENT MINDSHARE

Off-site DC (finger services only)

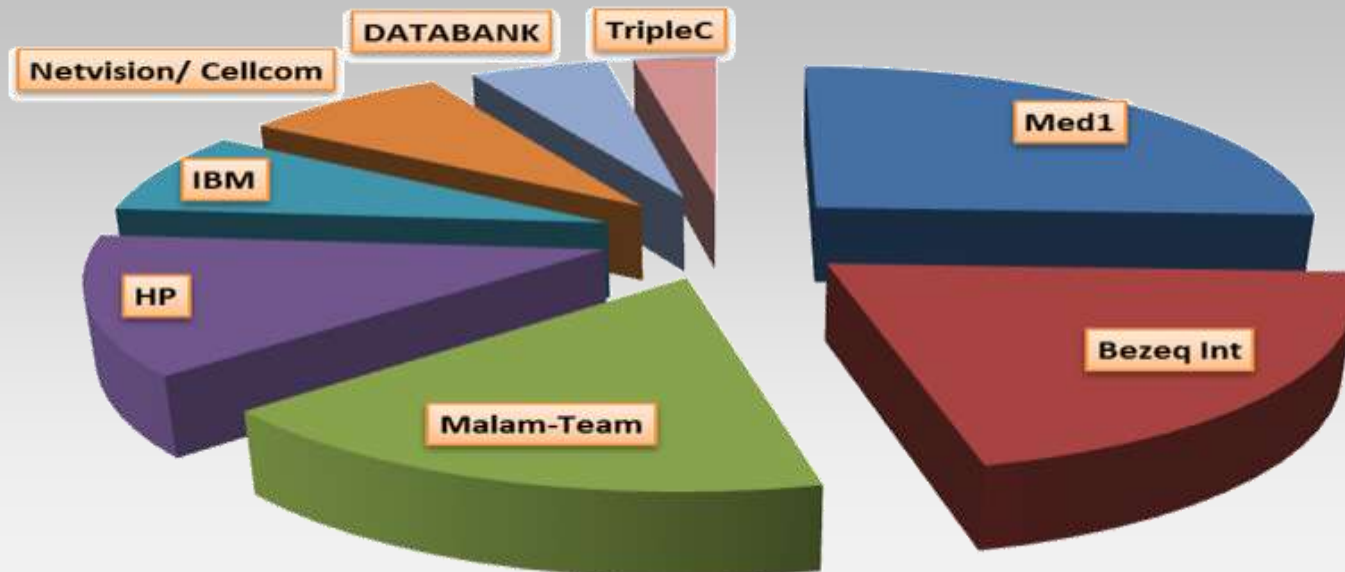

Off-site DC (fullservice, operational/DRP)

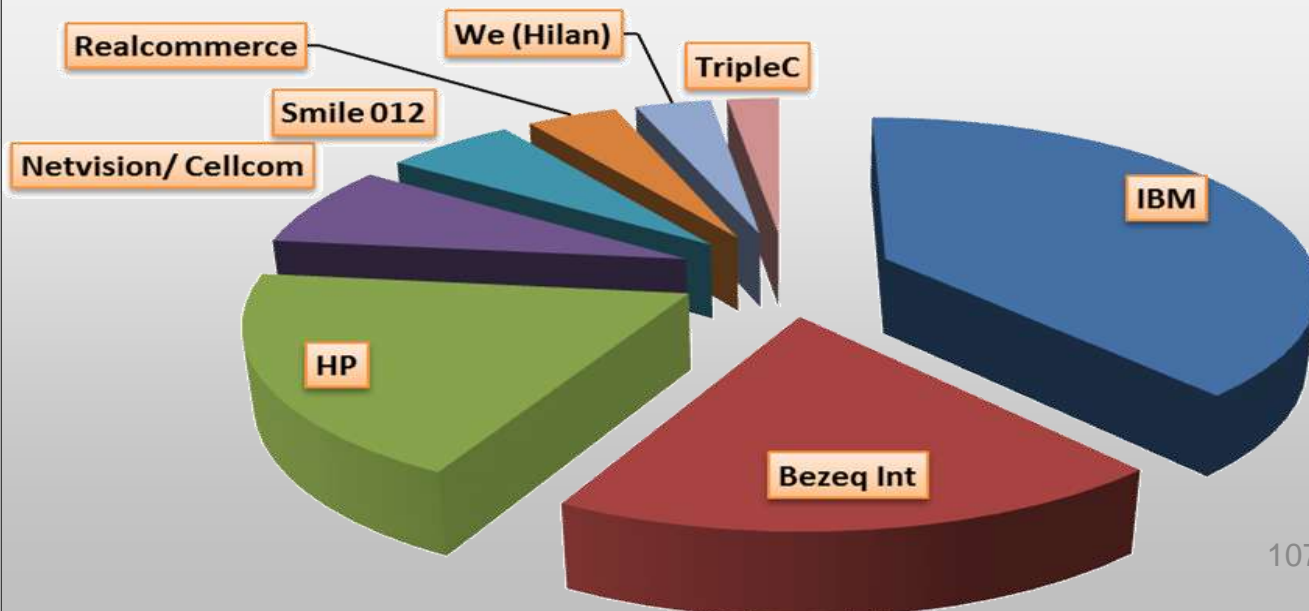

Comparison Outsourcing Market 2012

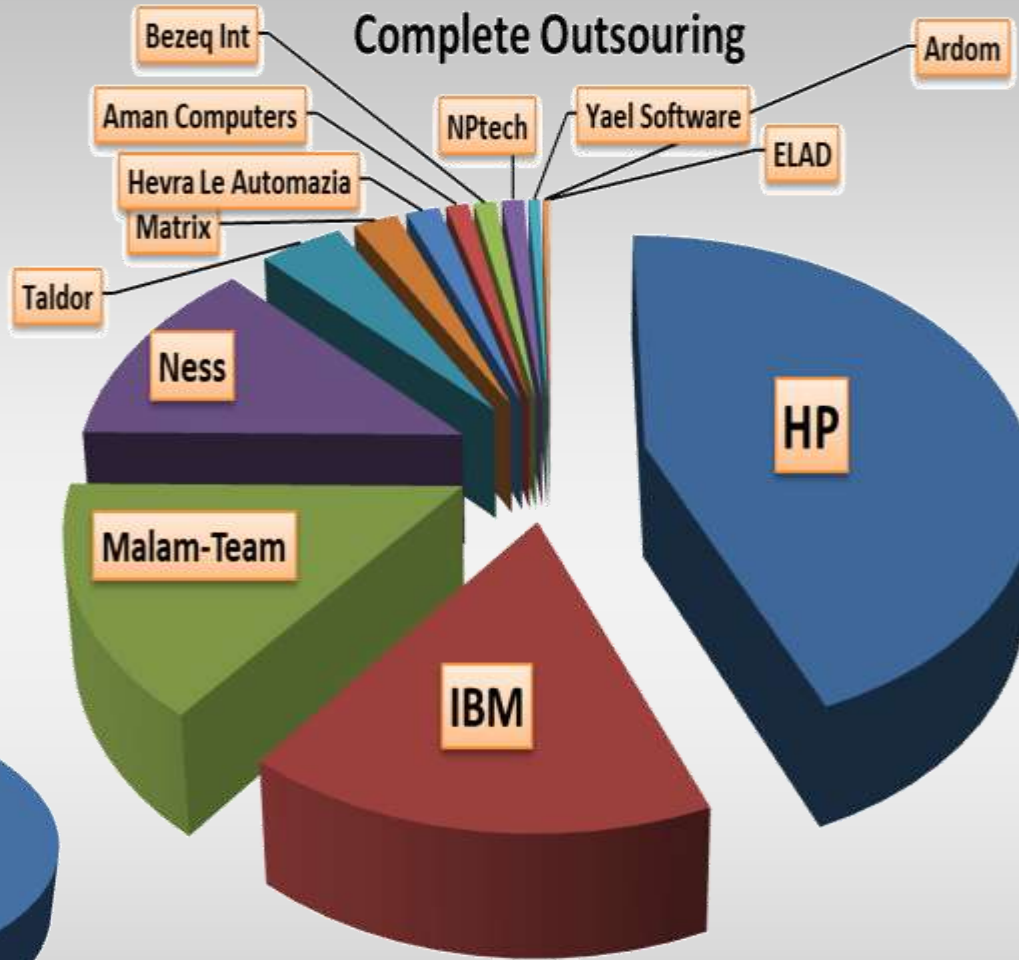

Application Outsourcing

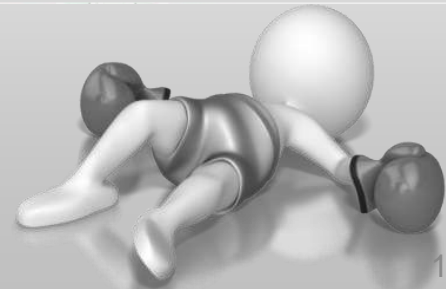
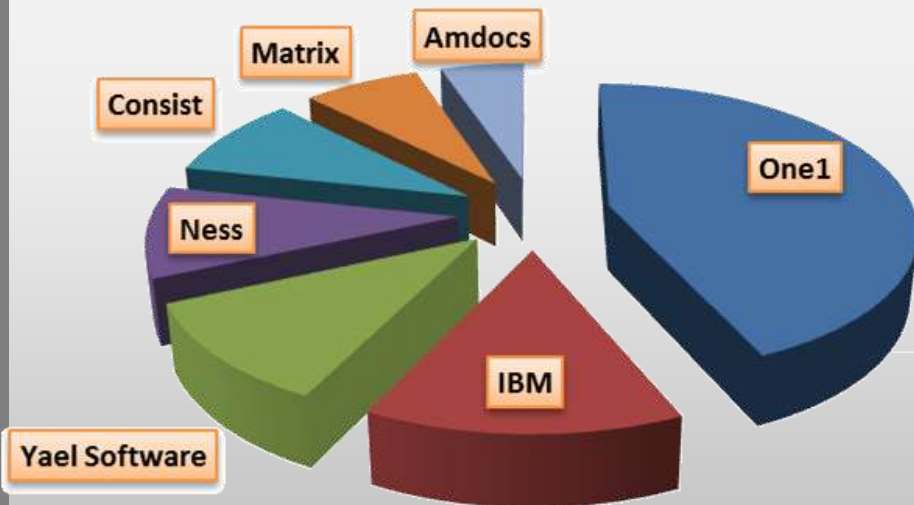

Comparison Outsourcing

Market 2 2012

Storage Management Outsourcing

DBA Outsourcing Services

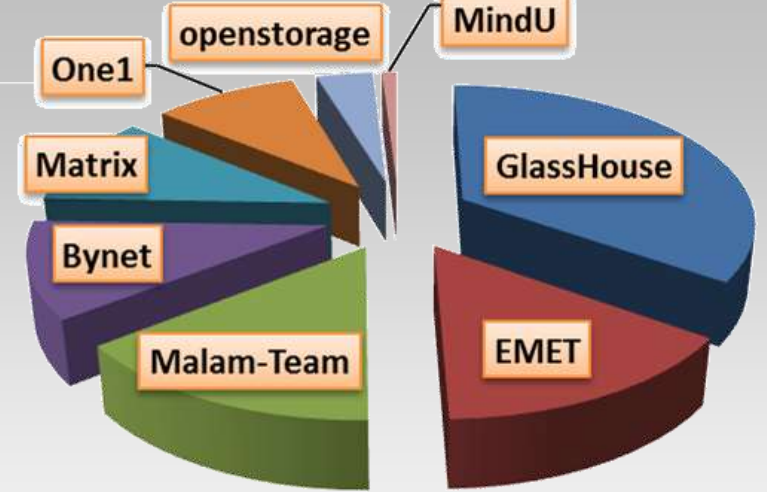
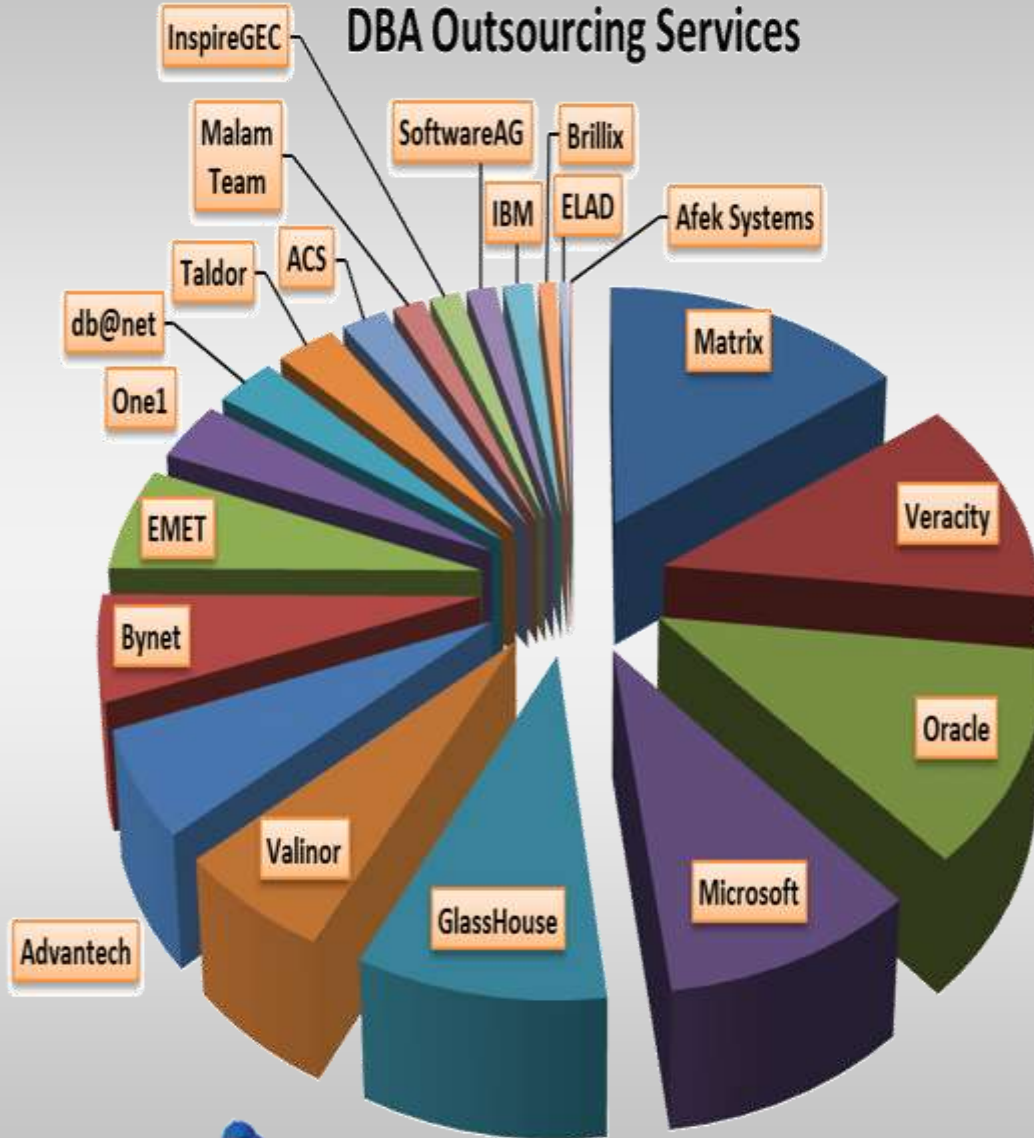

Call Center/Help Desk Outsourcing

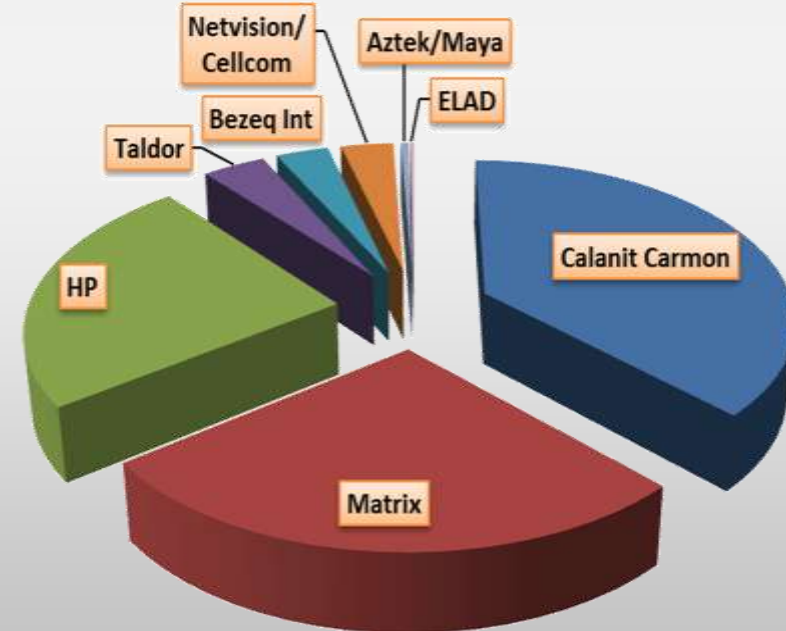

Value Added Services Categories 4

| | | | |
|--------------------|---|--|---------------------------------------|
| Cloud Services | BP as a Service BPaaS(salaries, call centers, etc) | תהליך עסקי במודל מחשוב ענן (משכורות, מרכזי שירות) | מחשוב ענן (הכוונה לשימוש בשירותי ענן) |
| | Platform as a Service PaaS | פיתוח והרצה במודל מחשוב ענן (PAAS) | |
| | Software as a Service SaaS | אפליקציות במודל מחשוב ענן (SaaS) | |
| | Infrastructure as a Service IaaS | תשתיות במודל מחשוב ענן (IaaS) | |
| Staff augmentation | Gulgalot | "גולגלות" - הניהול באחריות הלקוח | נוח אדם/קבלנים |
| | Nearshore | נרשור | |

We rank VENDORS by
REVENUE
and
CLIENT MINDSHARE

All amounts in M \$ USD

Cloud Services Market



| 2011 | | 2012 | | 2013 | |
|--------------|--------------|--------------|---------------|--------------|---------------|
| 100.0 | 2.00% | 102.0 | 3.92% | 106.0 | BPaaS |
| 15.0 | 33.33% | 20.0 | 75.00% | 35.0 | PaaS |
| 40.0 | 5.00% | 42.0 | 42.86% | 60.0 | SaaS |
| 18.0 | 11.11% | 20.0 | 75.00% | 35.0 | IaaS |
| 173.0 | 6.36% | 184.0 | 28.26% | 236.0 | totals |

We rank VENDORS by
REVENUE
 and
CLIENT MINDSHARE

All amounts in M \$ USD



Comparison

XaaS Market 2012

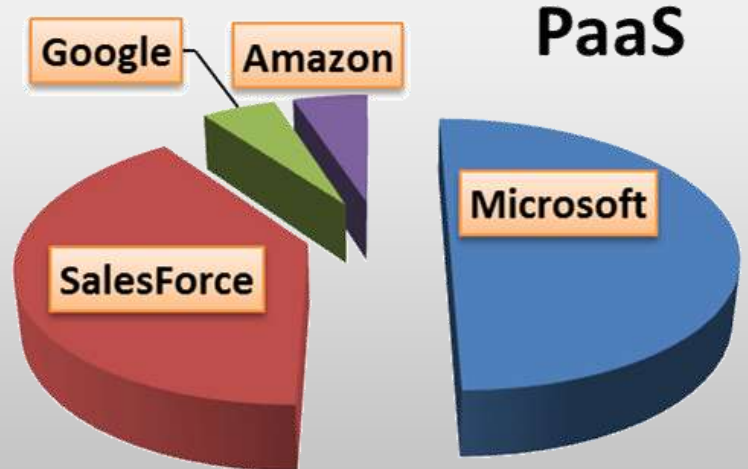
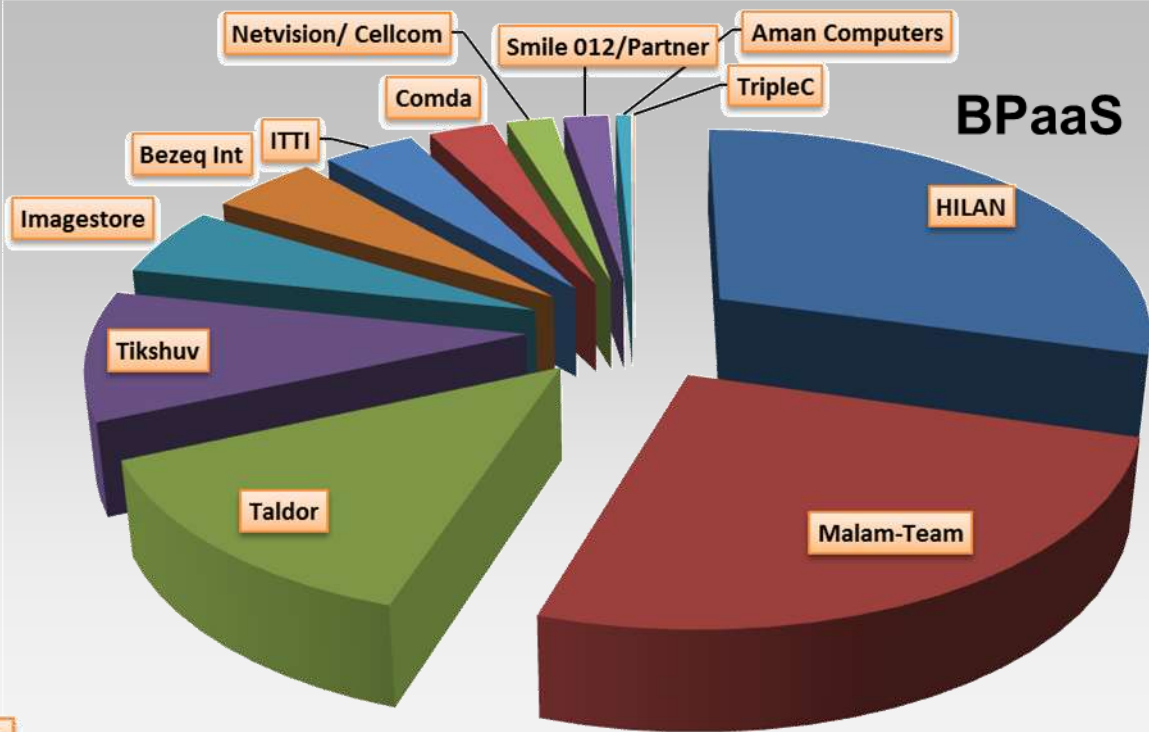
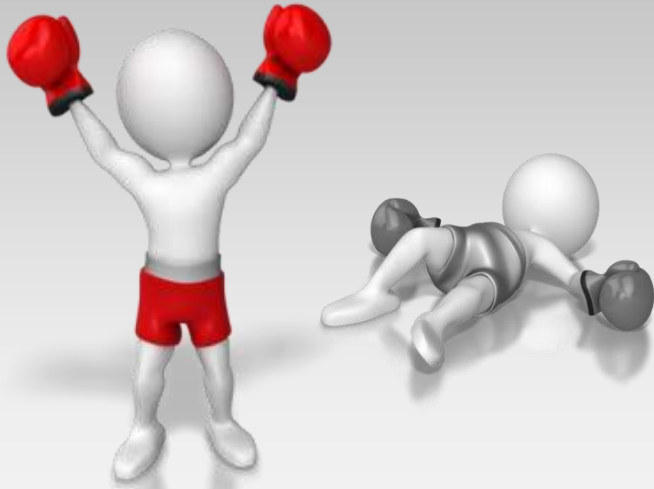

We rank VENDORS by
REVENUE
 and
CLIENT MINDSHARE

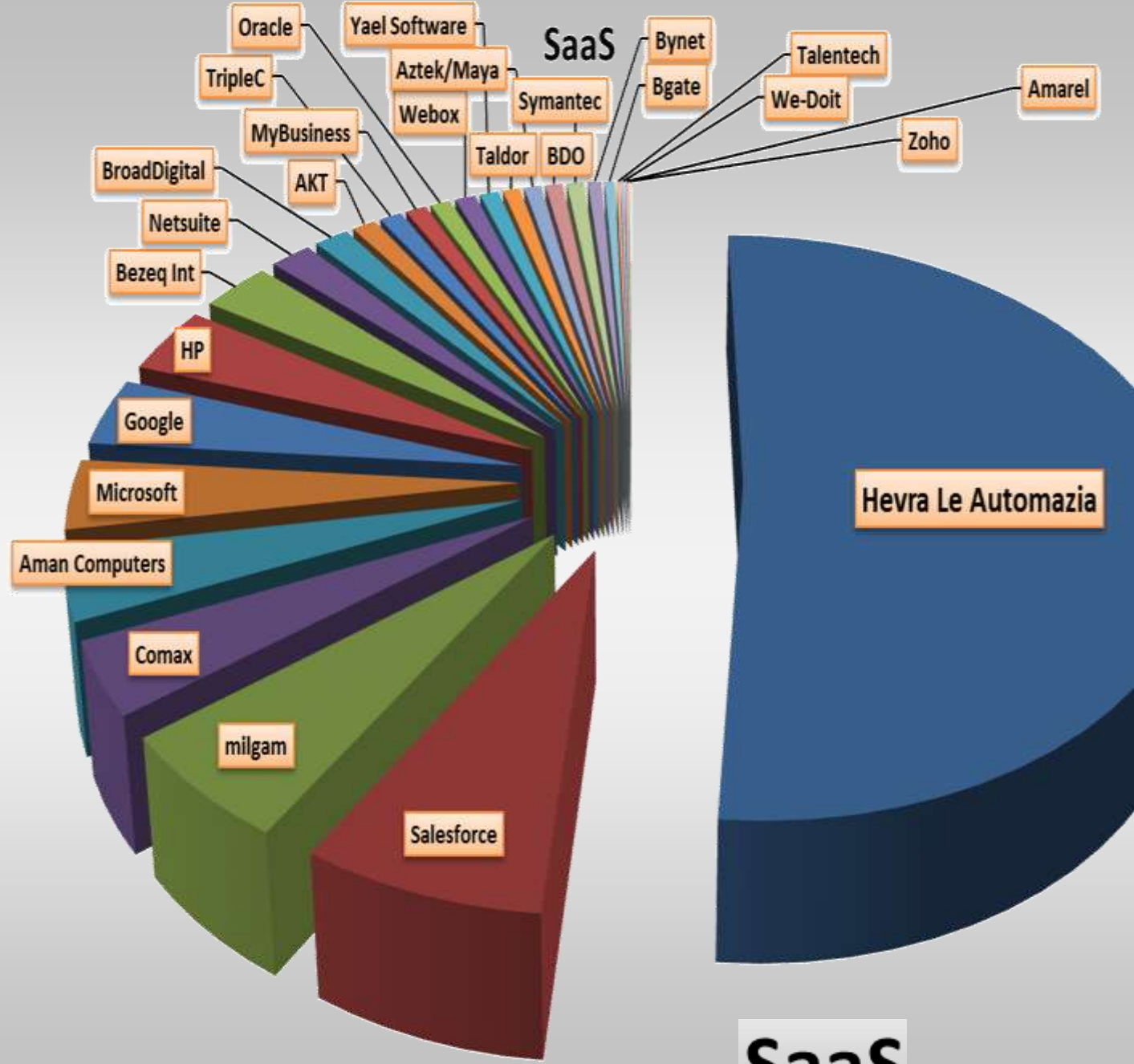

Staff Augmentation Market



| 2011 | | 2012 | | 2013 | |
|-------|---------|-------|--------|-------|--------------------|
| 350.0 | -12.86% | 305.0 | -9.84% | 275.0 | Staff Augmentation |
| 120.0 | 25.00% | 150.0 | 23.33% | 185.0 | Nearshore |
| 470.0 | -3.19% | 455.0 | 1.10% | 460.0 | TOTAL |

We rank VENDORS by
REVENUE
 and
 CLIENT MINDSHARE

All amounts in M \$ USD



Comparison Staff Augmentation Market 2012

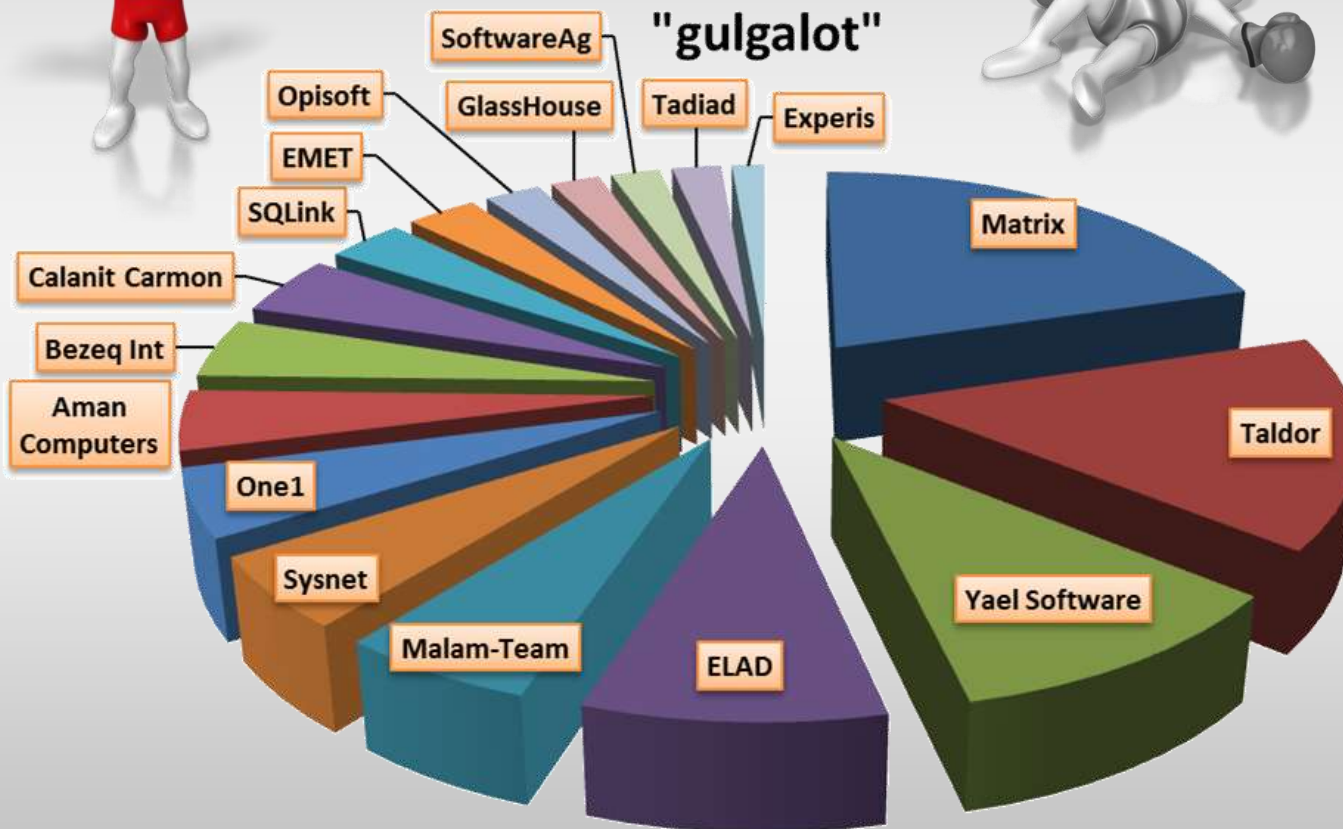

| |
|--------------------|
| HP |
| LogOn |
| Tvuna milenium |
| Hevra Le Automazia |
| Top Group |
| C.BIT |
| Dor -IT |
| SmartIT |
| Aztek/Maya |
| Data Cube |
| Comsec |
| Aginix |
| Eternity |
| GBS |
| MindU |
| Active View |
| Pilat |
| IntegrITy |
| Brillix |

We rank VENDORS by
REVENUE
and
CLIENT MINDSHARE

Near-Shore Services

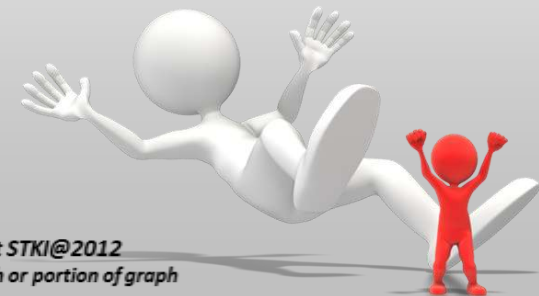
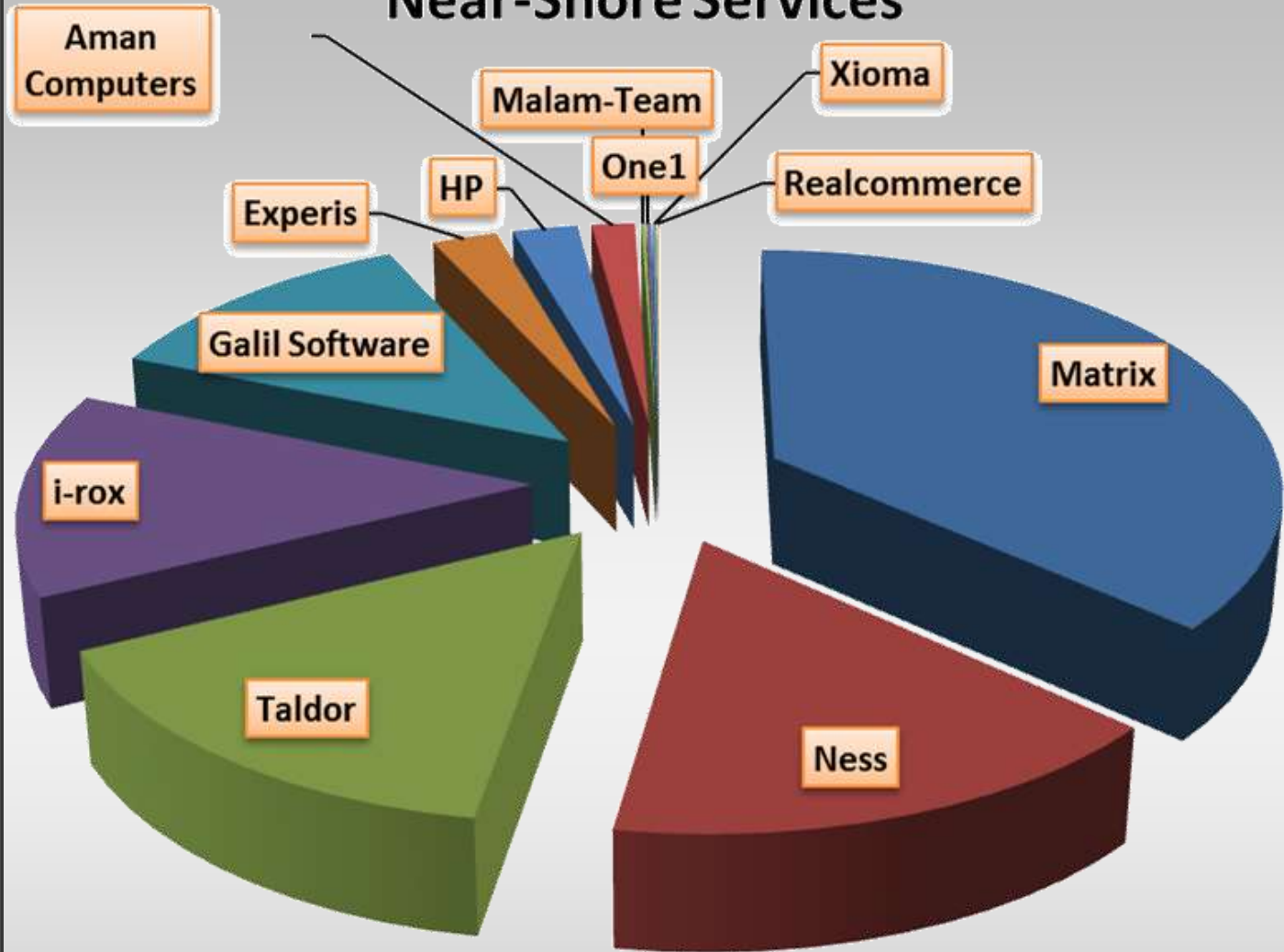

More Information?

